

OPTI FIT

JAKA-BKL GmbH
Jaka Straße 3
D-32351 Stemwede-Wehden

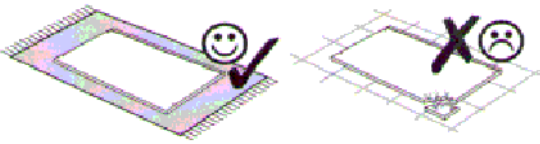

1 → 2 → 3 ...

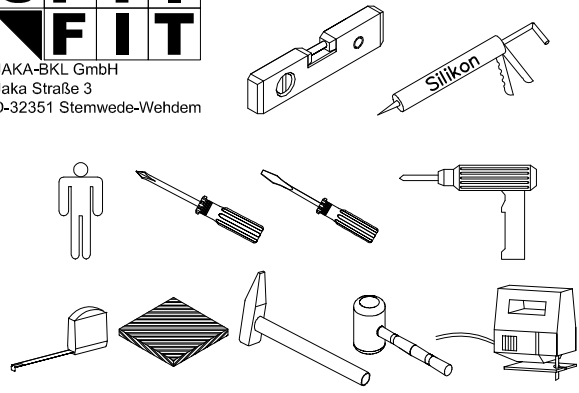
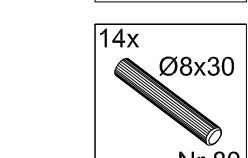
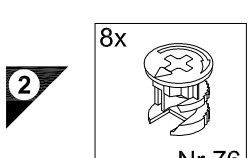
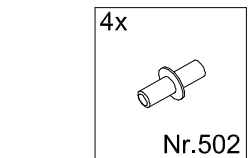
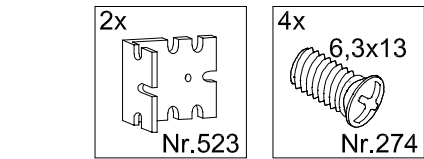
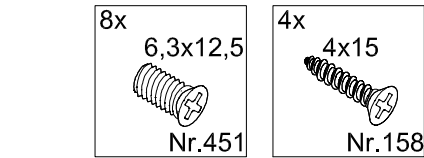
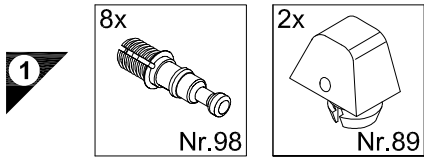

Service-Hotline
01805-678101
0,14€ pro Minute
++49 für Österreich
Auslandstarif pro Minute
service@jaka-bkl.de
voor Nederland en België
00800-40119350
benelux@jaka-bkl.de

Montageanleitung

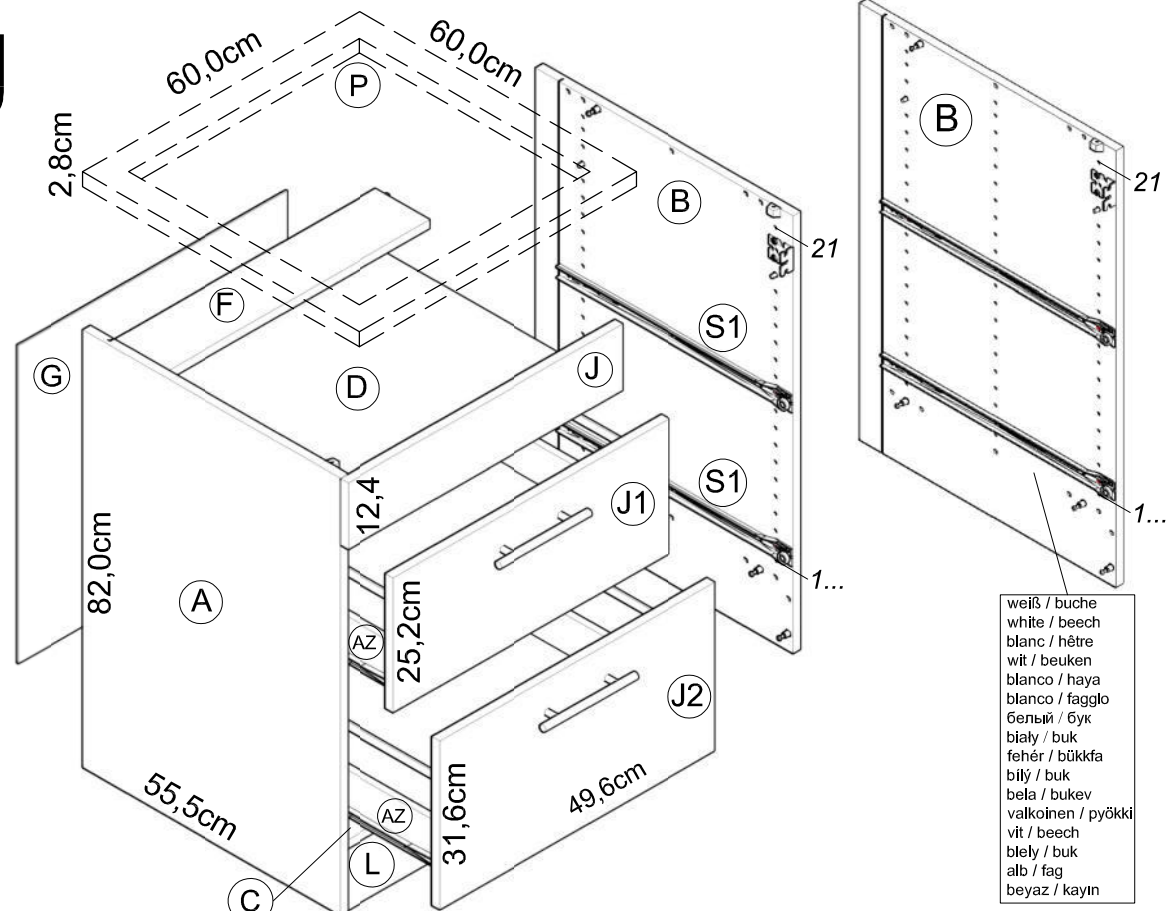
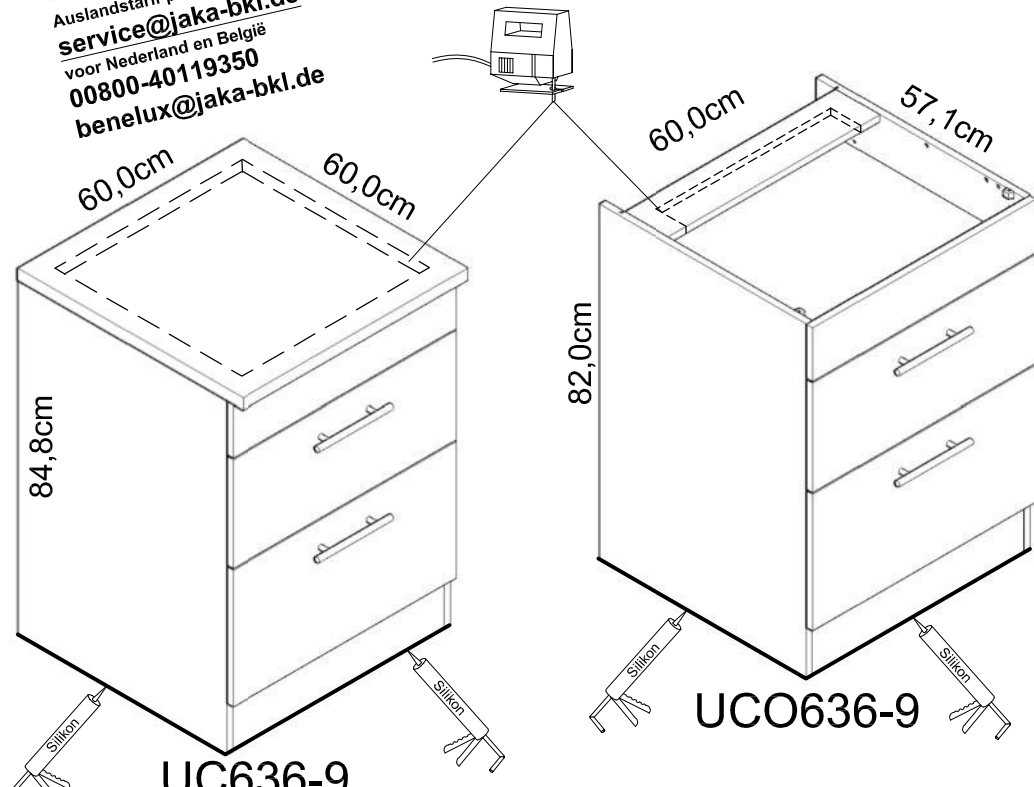

weiß / buche
white / beech
blanc / hêtre
wit / beuken
blanco / haya
bianco / faggio
белый / бук
biały / buk
fehér / bükkfa
bílý / buk
bela / bukev
valkoinen / pyökki
vit / beech
biely / buk
alb / fag
beyaz / kayın

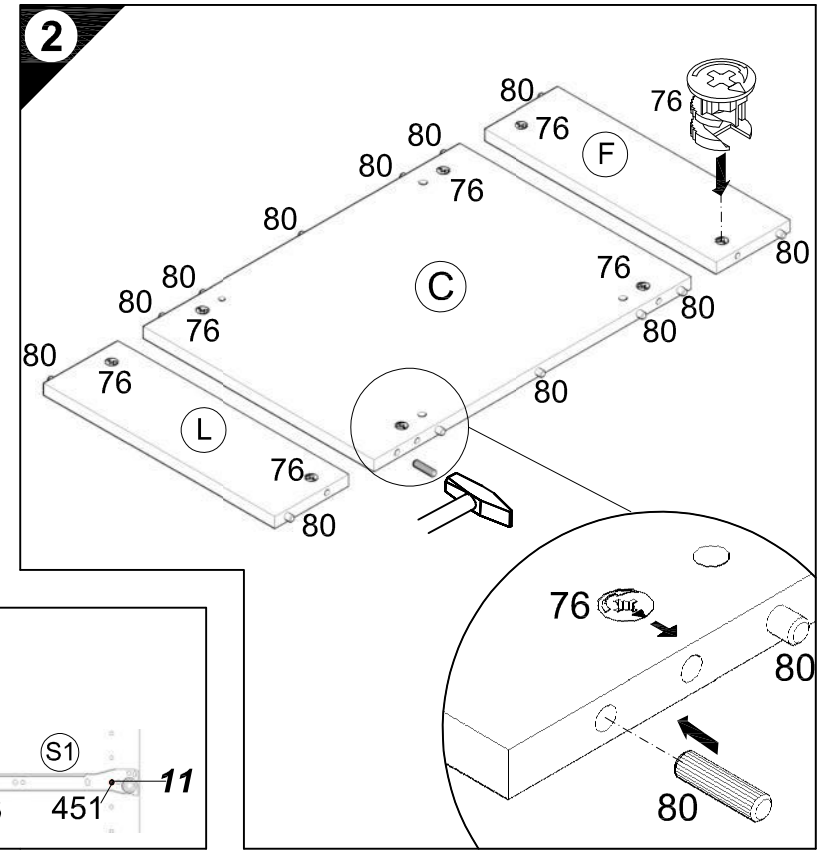
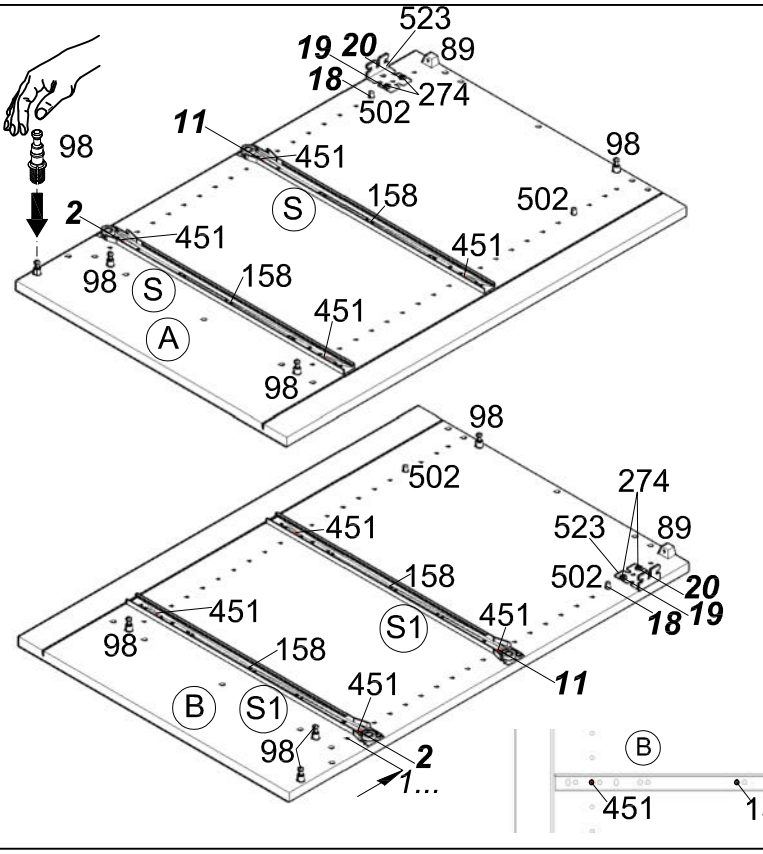
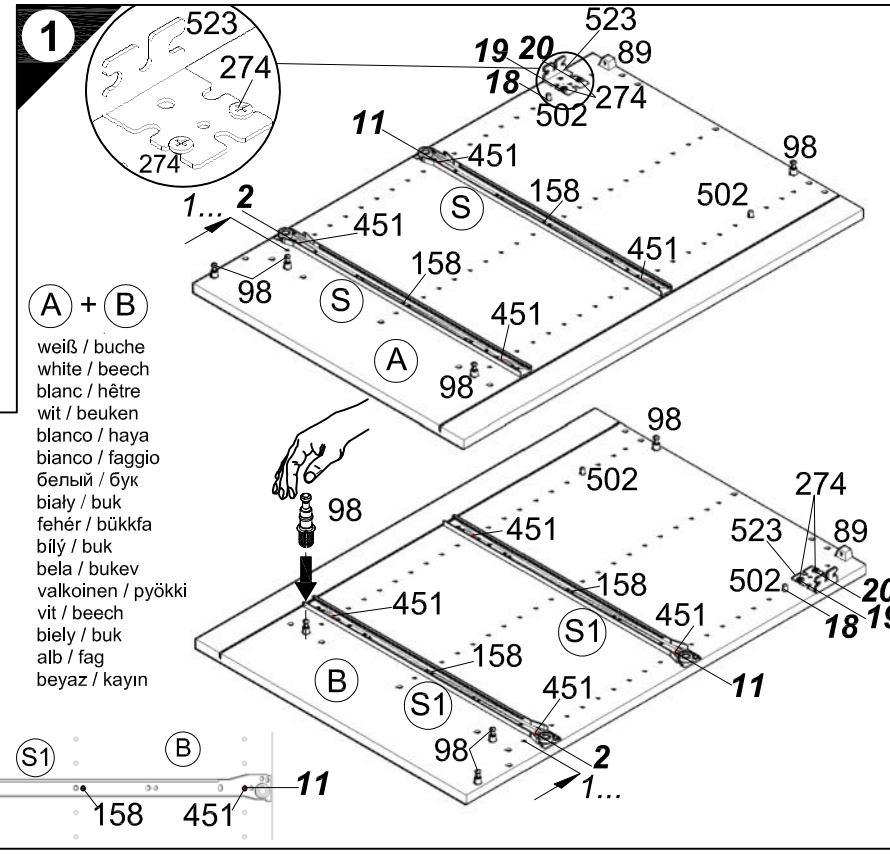

Ersatzteile/Spare parts/pièces de rechange/Reserveonderdelen/Piezas de recambio/Ricambi/Запасные части/Części zamienne/pótkatárszek/Náhradní části/Nadomestni deli/varaosat/reservdelar/náhradné diely/Utilizați piese de schimb/Yedek parçalar

60cm UC636-9	[A] E961021	[B] E961022	[C] E954223	[D] E950303	[F] E970973	[G] E970092	[J] E940562	[J1] E940591	[J2] E940645	[L] E970973	[P] E540103	[S] E946155	[S1] E946155
weiß/buche UC636-9	[A] E981021	[B] E981022	[C] E954223	[D] E950303	[F] E970973	[G] E970092	[J] E940562	[J1] E940591	[J2] E940645	[L] E970973	[P] E540103	[S] E946155	[S1] E946155
white/beech.... UC636-9	[A] E981021	[B] E981022	[C] E954223	[D] E950303	[F] E970973	[G] E970092	[J] E940562	[J1] E940591	[J2] E940645	[L] E970973	[P] E540103	[S] E946155	[S1] E946155
60cm UCO636-9	[A] E961021	[B] E961022	[C] E954223	[D] E950303	[F] E970973	[G] E970092	[J] E940562	[J1] E940591	[J2] E940645	[L] E970973	[S] E946155	[S1] E946155	
weiß/buche UCO636-9	[A] E981021	[B] E981022	[C] E954223	[D] E950303	[F] E970973	[G] E970092	[J] E940562	[J1] E940591	[J2] E940645	[L] E970973	[S] E946155	[S1] E946155	
white/beech.... UCO636-9	[A] E981021	[B] E981022	[C] E954223	[D] E950303	[F] E970973	[G] E970092	[J] E940562	[J1] E940591	[J2] E940645	[L] E970973	[S] E946155	[S1] E946155	

1 → 2 → 3 ...

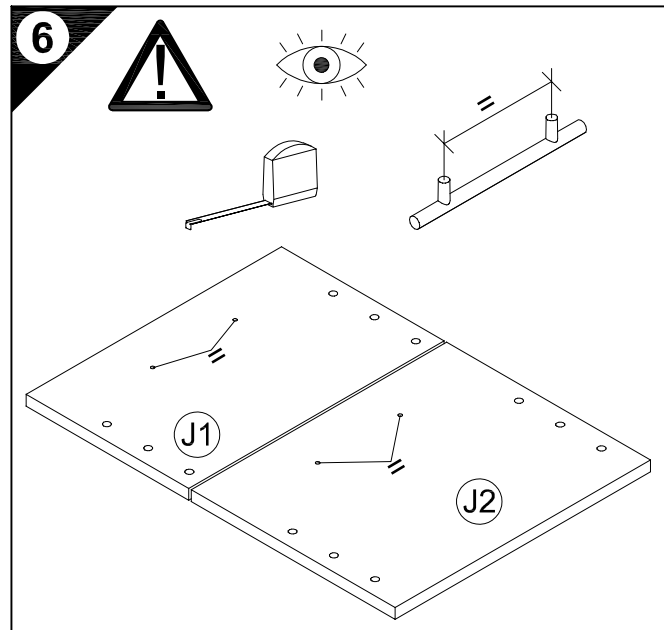
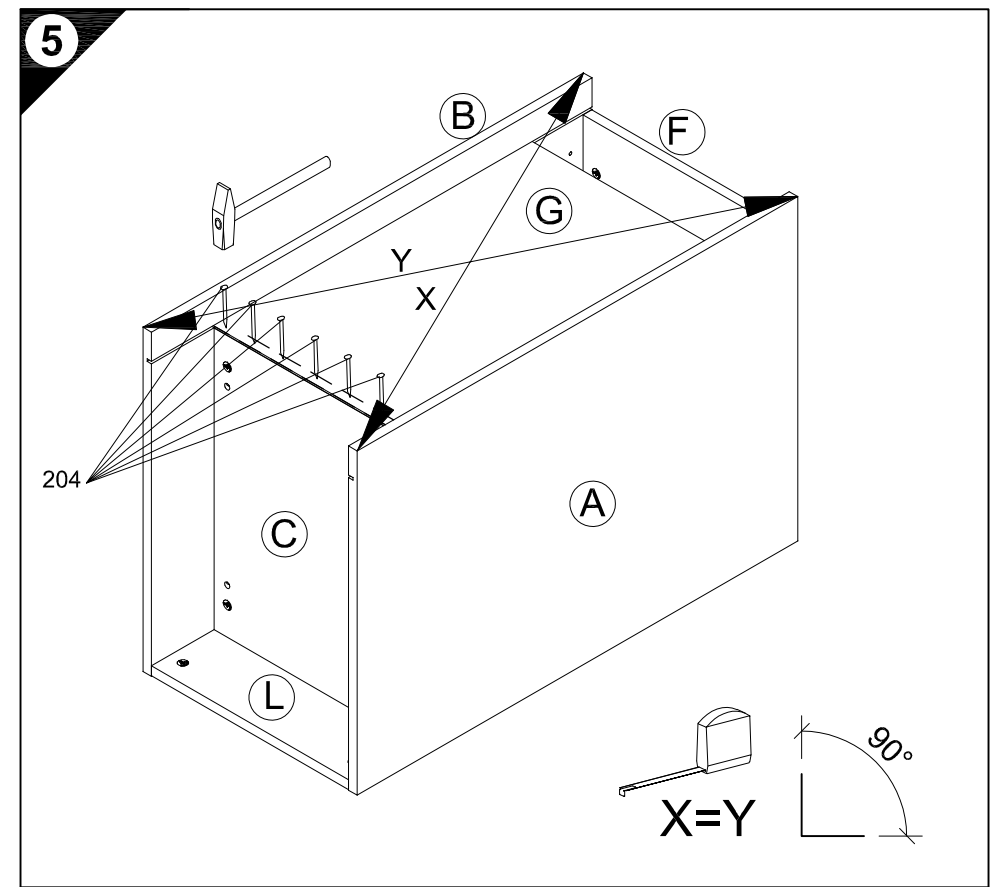
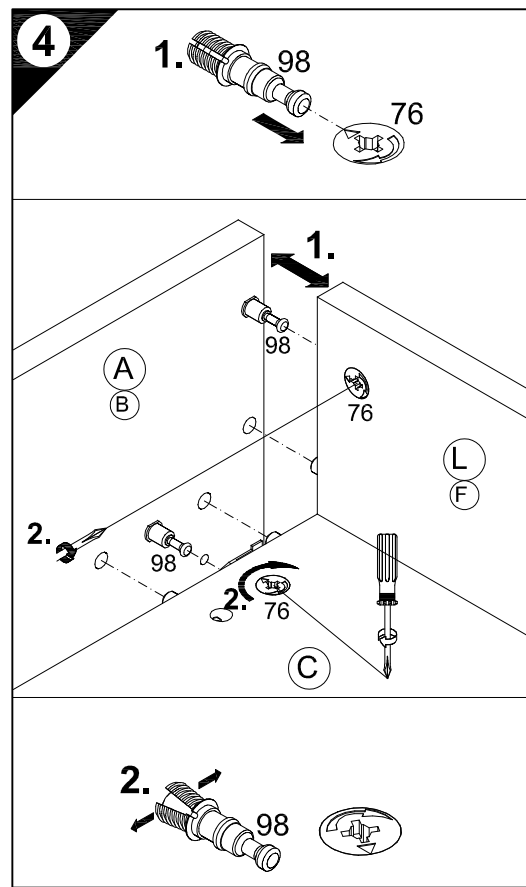
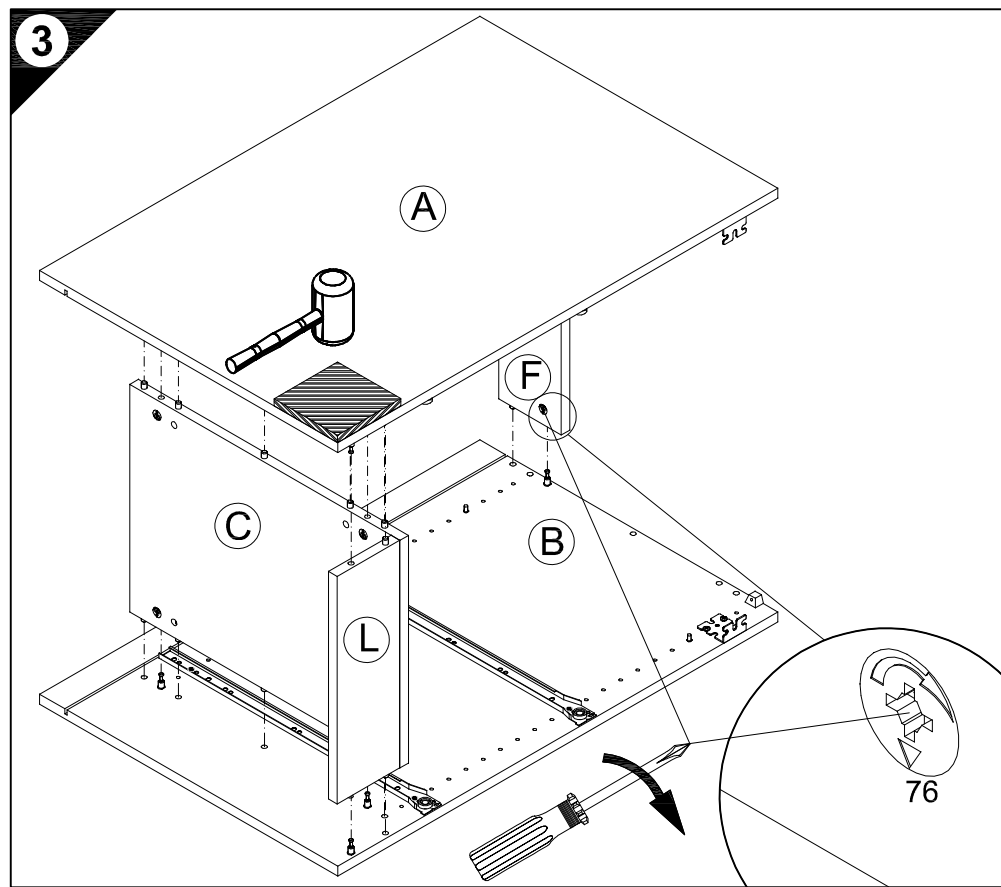
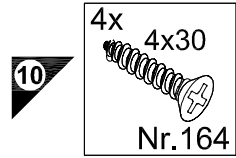
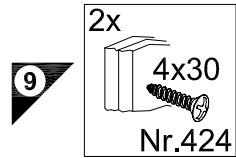
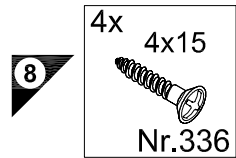
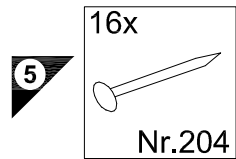

D Holzunterlage verwenden!
Front andrücken, scharfen Bohrer verwenden
und mit wenig Druck durchbohren!

GB Use a wooden base!
Press front down, use sharp drill bit
and, by applying slight pressure, drill a hole

F Utiliser un support en bois !
Appuyer sur la façade, utiliser un foret bien affûté
et percer en appliquant une faible pression !

NL Houten onderlegger gebruiken!
Druk het front aan, gebruik een scherpe boor
en oefen bij het boren weinig druk uit!

E ¡Utilizar una base de madera!
¡Presionar el frente, utilizar una broca afilada
y taladrar con poca presión!

I Utilizzare una base di legno!
Appoggiare la facciata, utilizzare una punta di trapano affilata
e trapanare esercitando solo una leggera pressione!

RUS Использовать деревянную подложку!
Прижать фасад, использовать острое сверло
и просверлить с незначительным давлением!

PL Używać podkładkę z drewna!
Docisnąć front, użyć ostrego wiertła
i przewiercić, używając małej siły nacisku!

H Alkalmazáson fa alátétet!
Nyomja le az előlapot, használjon éles fúrót,
és kis nyomással fúrja át!

CZ Použijte dřevěný podklad!
Přitlačte čelo, použijte ostrý vrták
a provrtajte pomocí malého tlaku!

SLO Uporabite leseno podlago!
Pritisnite ličnico ter z ostrim svedrom
in z majhnim pritiskom izvrtajte luknjo!

FIN Käytä puualustaa!
Paina etulevy paikoilleen, käytä terävää poranterää
ja poraa reikä vain kevyesti painamalla!

S Använd ett träunderlag!
Tryck fronten mot underlaget, använd vass borrh
och borra igenom med ett lätt tryck!

SK Použite drevený podklad!!
Přitlačte front, použite ostrý vrták a prevrtajte miernym tlakom!

RO suport de lemn! Împingeți frontul, utilizați un burghiu ascuțit
și perforați exercitând doar o presiune redusă!

TR Ahşap taban kullanın!
Önden bastırın, keskin matkap ucu kullanın ve az basınç
uygulayarak delin!

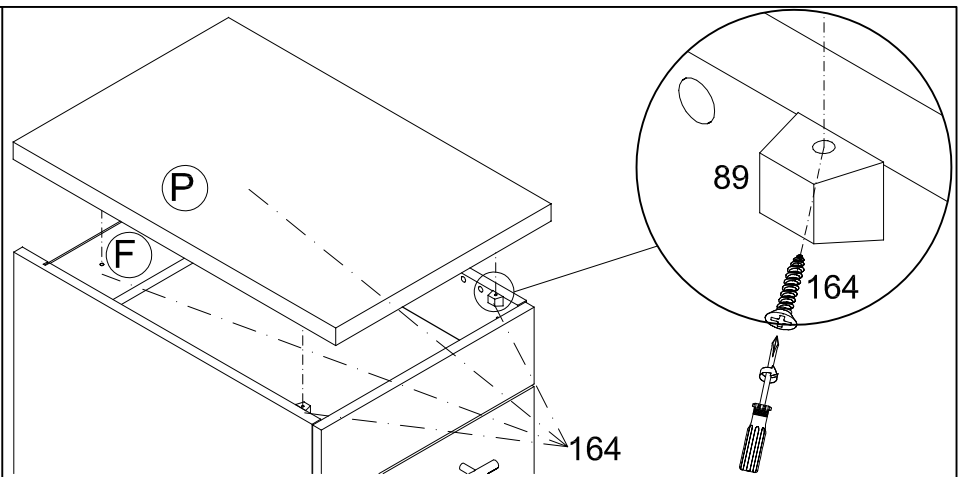
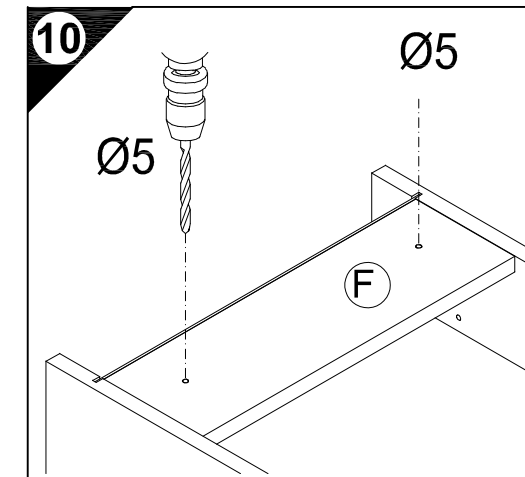
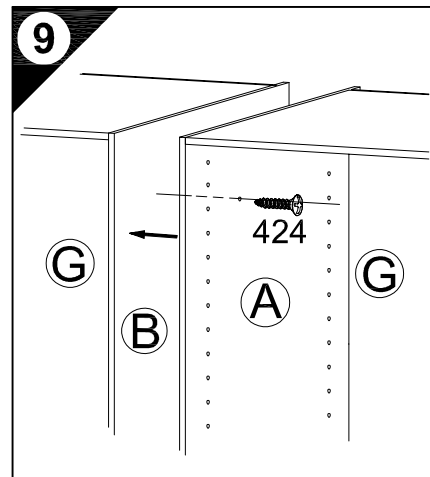
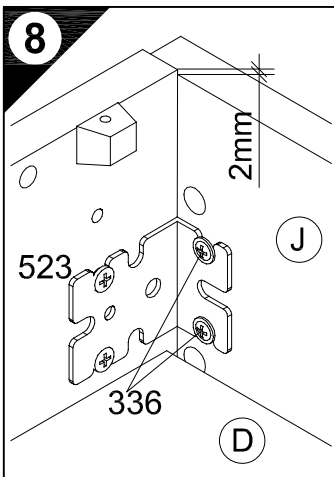
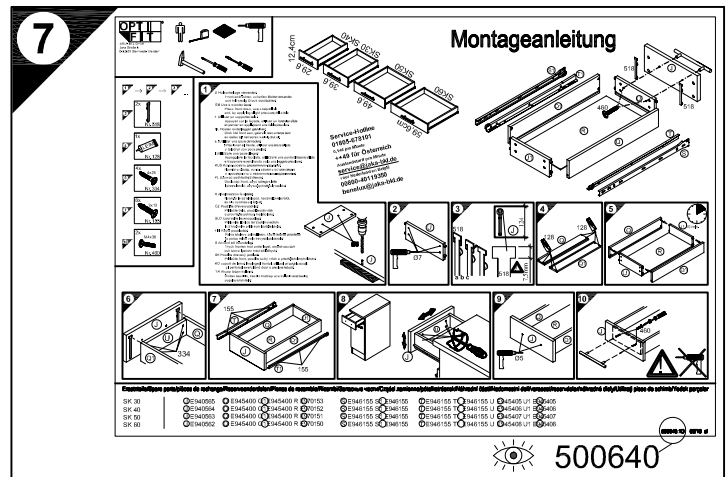
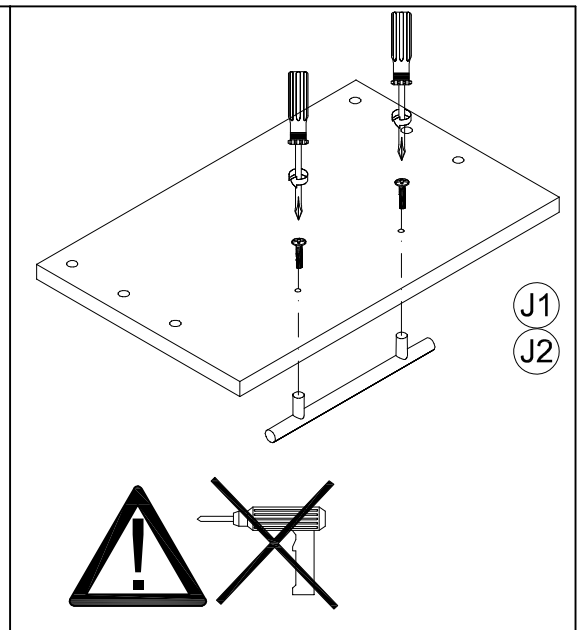
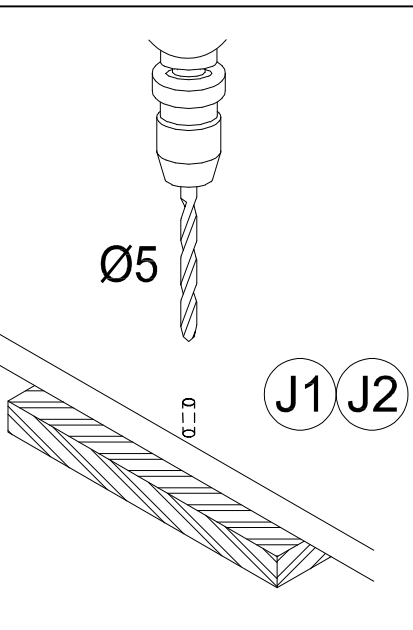

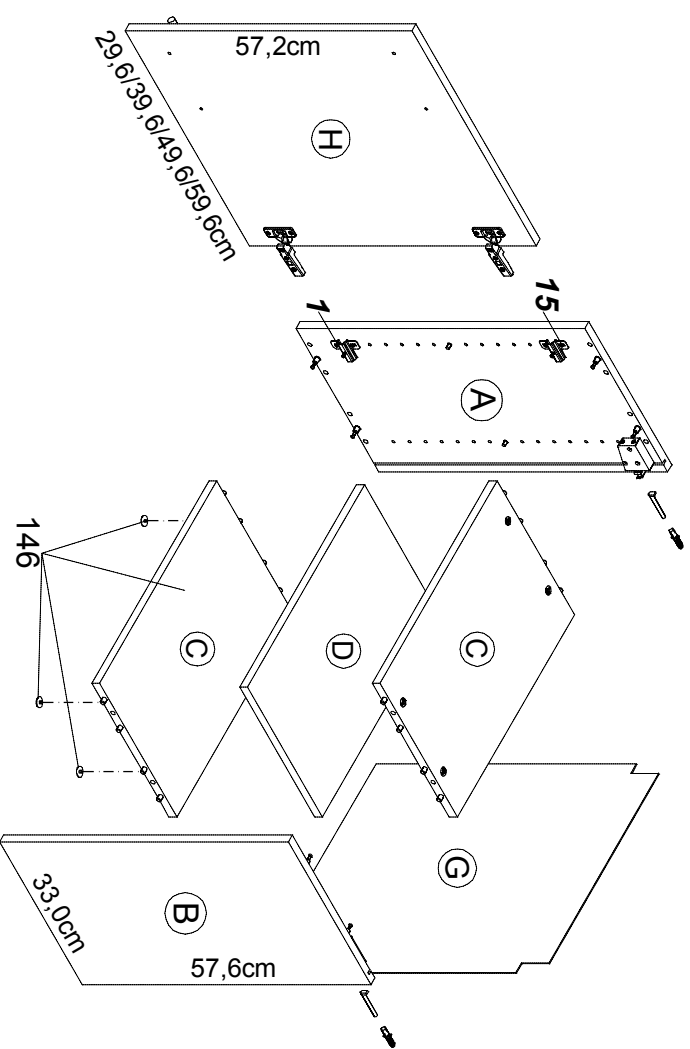
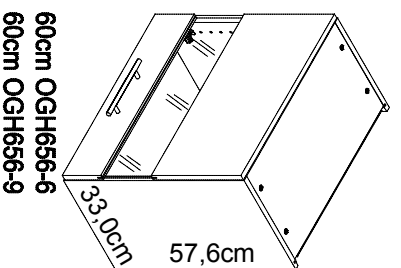
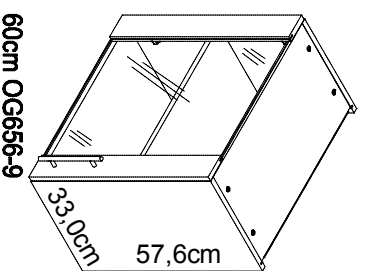
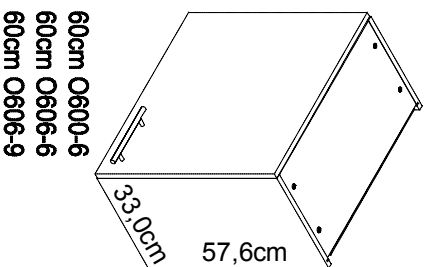
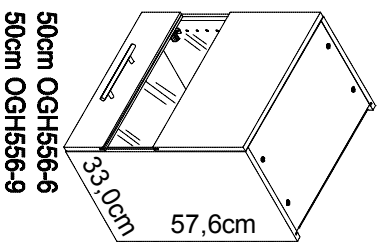
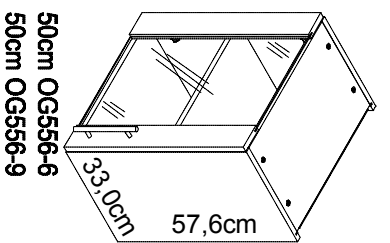
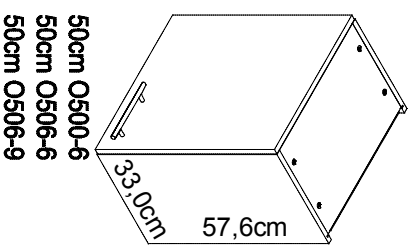
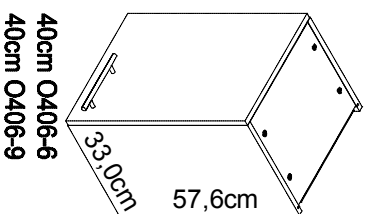
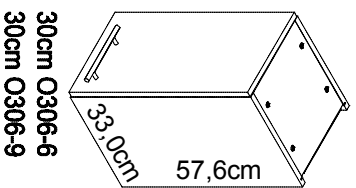
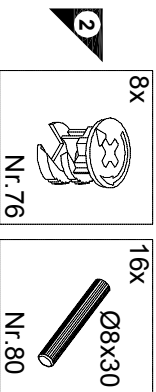
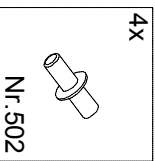
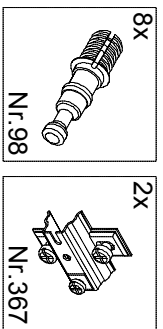
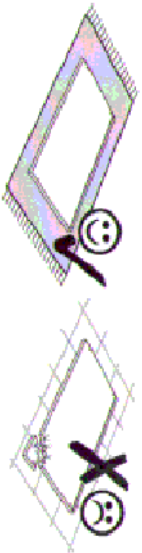
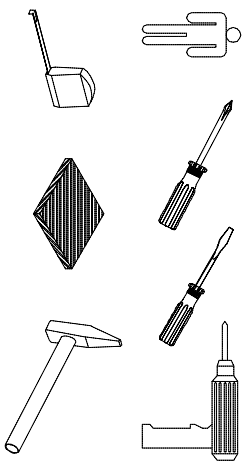

Montageanleitung

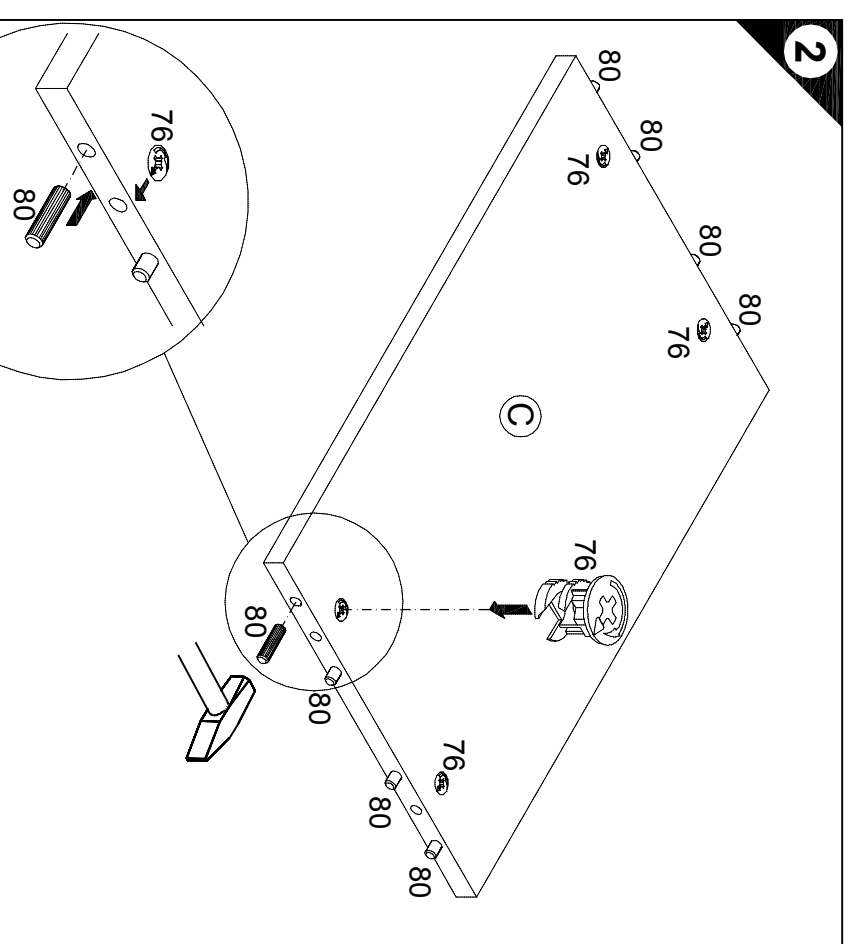
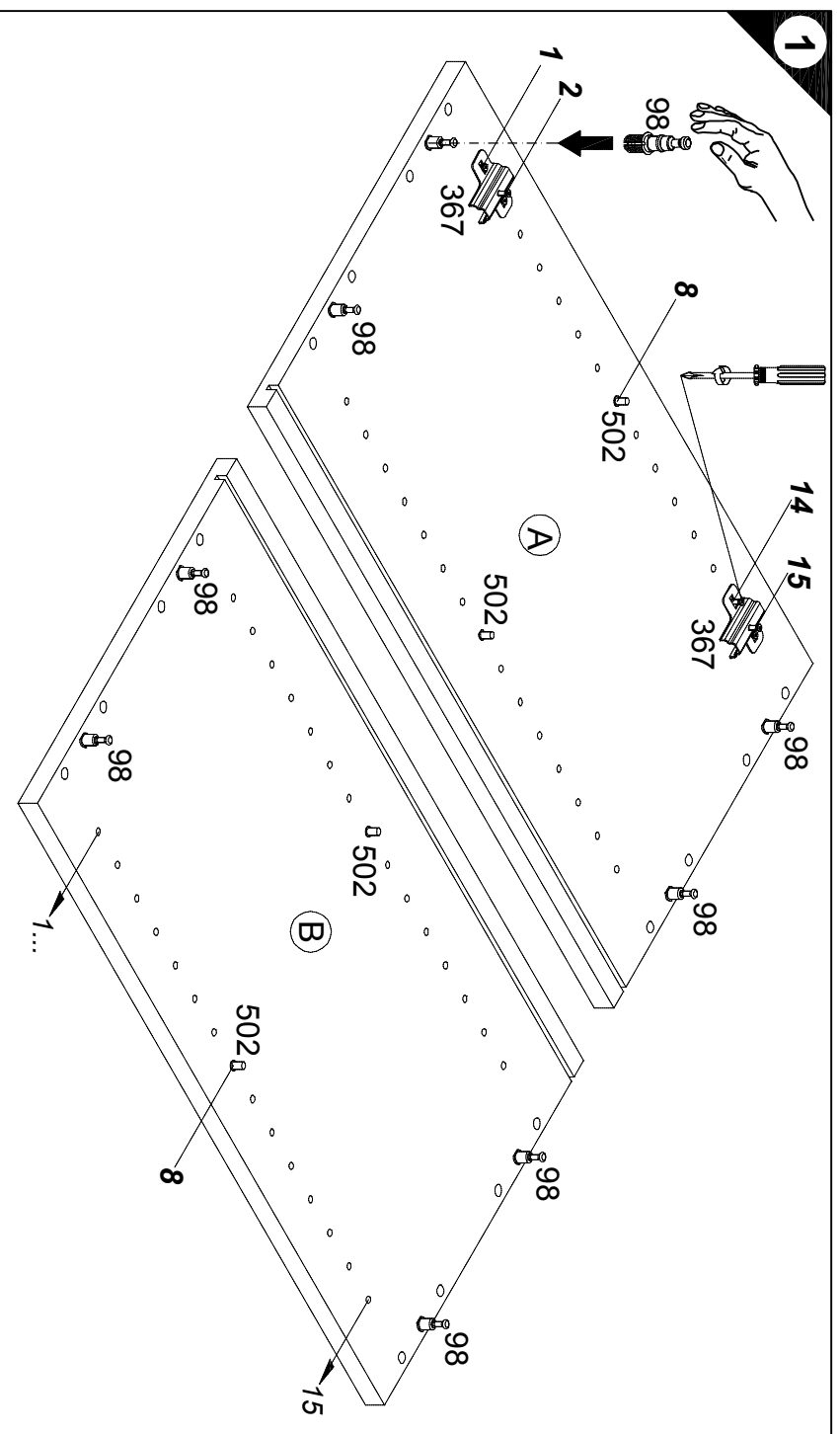

Service-Hotline
01805-678101
0,14€ pro Minute
+ +49 für Österreich
Auslandstarif pro Minute
service@jaka-bkl.de
voor Nederland en België
00800-40119350
benelux@jaka-bkl.de

- | | | | | | | |
|-----------------|-------------|-------------|-------------|-------------|-------------|-------------|
| 30cm O306-6/ -9 | (A) E940036 | (B) E940036 | (C) E941236 | (D) E940336 | (G) E971015 | (H) E940614 |
| 40cm O406-6/ -9 | (A) E940036 | (B) E940036 | (C) E941235 | (D) E940335 | (G) E971014 | (H) E940613 |
| 50cm O500 | (A) E940036 | (B) E940036 | (C) E941234 | (D) E940334 | (G) E970032 | (H) E980612 |
| 50cm O506-6/ -9 | (A) E940036 | (B) E940036 | (C) E941234 | (D) E940334 | (G) E970032 | (H) E940612 |
| 60cm O600 | (A) E940036 | (B) E940036 | (C) E941233 | (D) E940333 | (G) E971012 | (H) E980611 |
| 60cm O606-6/ -9 | (A) E940036 | (B) E940036 | (C) E941233 | (D) E940333 | (G) E971012 | (H) E940611 |

- | | | | | | | |
|-------------------|-------------|-------------|-------------|-------------|-------------|-------------|
| 50cm OG556-6/ -9 | (A) E940036 | (B) E940036 | (C) E941234 | (D) E940334 | (G) E970032 | (H) E940647 |
| 50cm OGH556-6/ -9 | (A) E940036 | (B) E940036 | (C) E941234 | (D) E940334 | (G) E970032 | (H) E940655 |
| 60cm OGH656-6/ -9 | (A) E940036 | (B) E940036 | (C) E941233 | (D) E940333 | (G) E971012 | (H) E980657 |
| 60cm OG656-9 | (A) E940036 | (B) E940036 | (C) E941233 | (D) E940333 | (G) E971012 | (H) E940657 |

1 → 2 → 3 ...

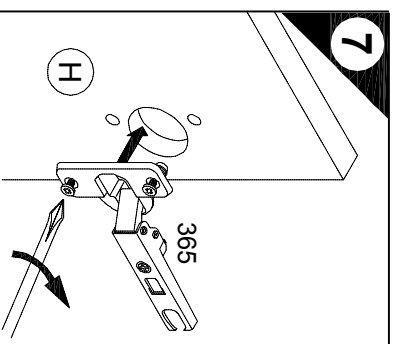
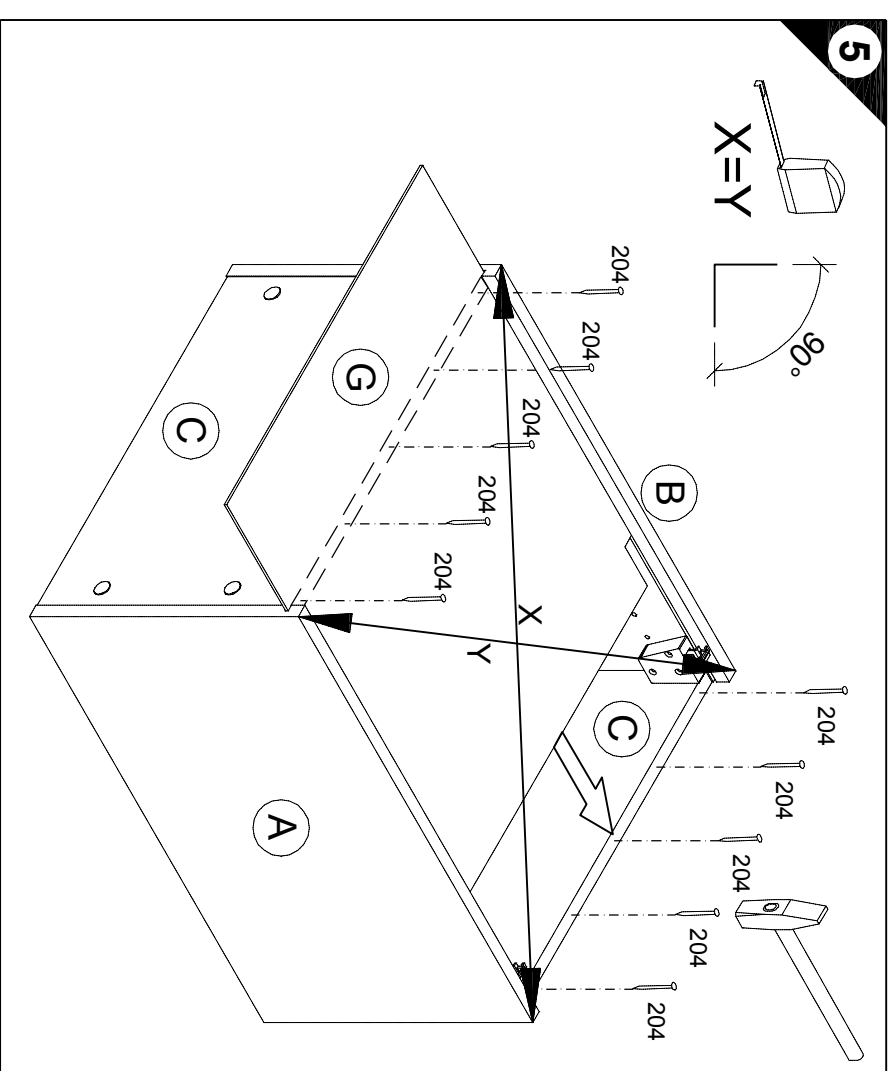
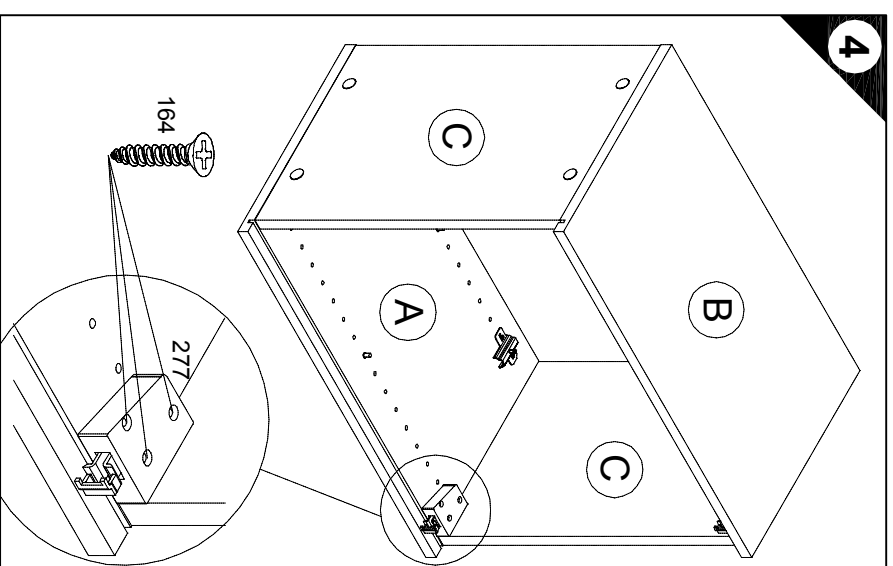
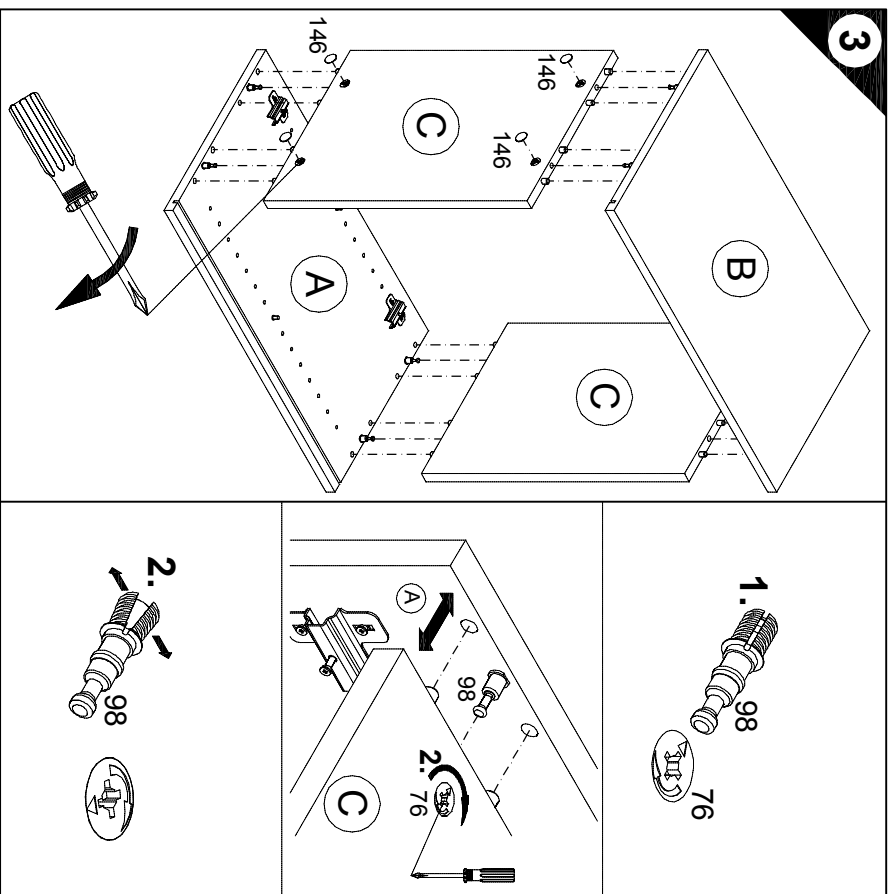
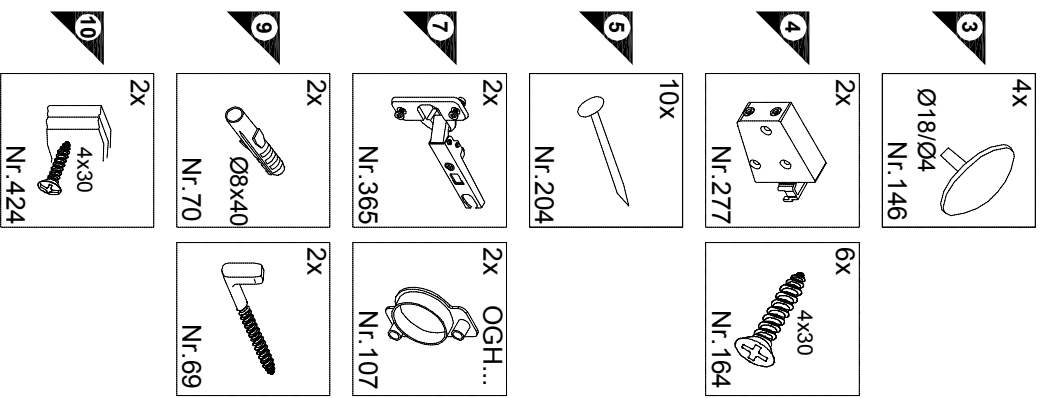

OGH556-6 / -9
OGH656-6 / -9

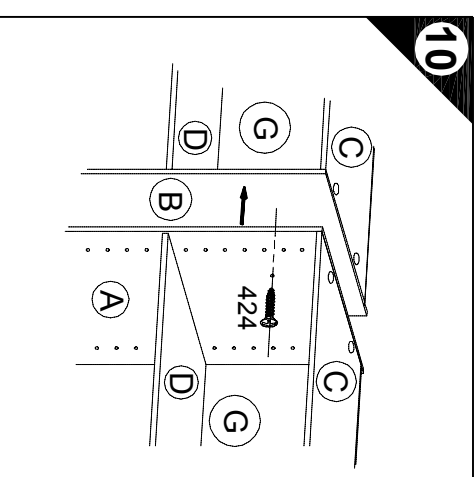
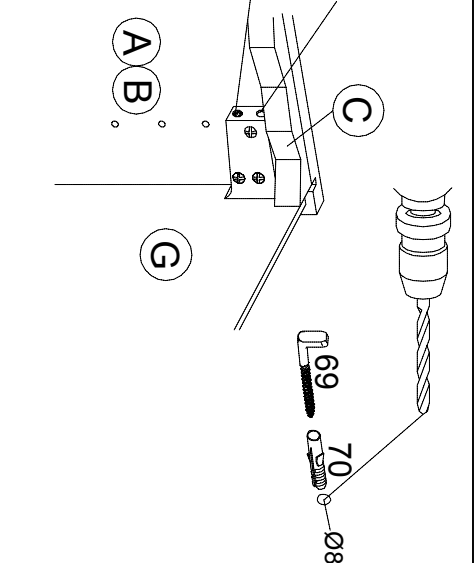
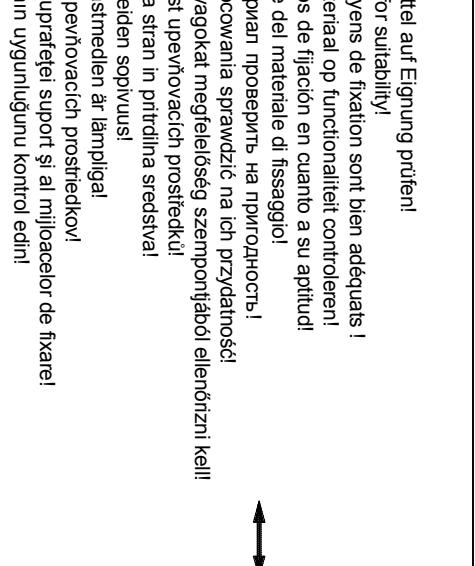
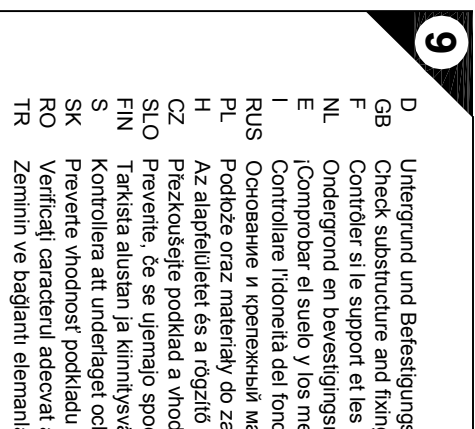
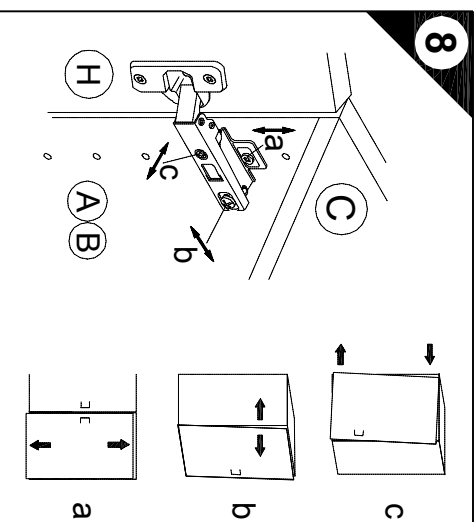
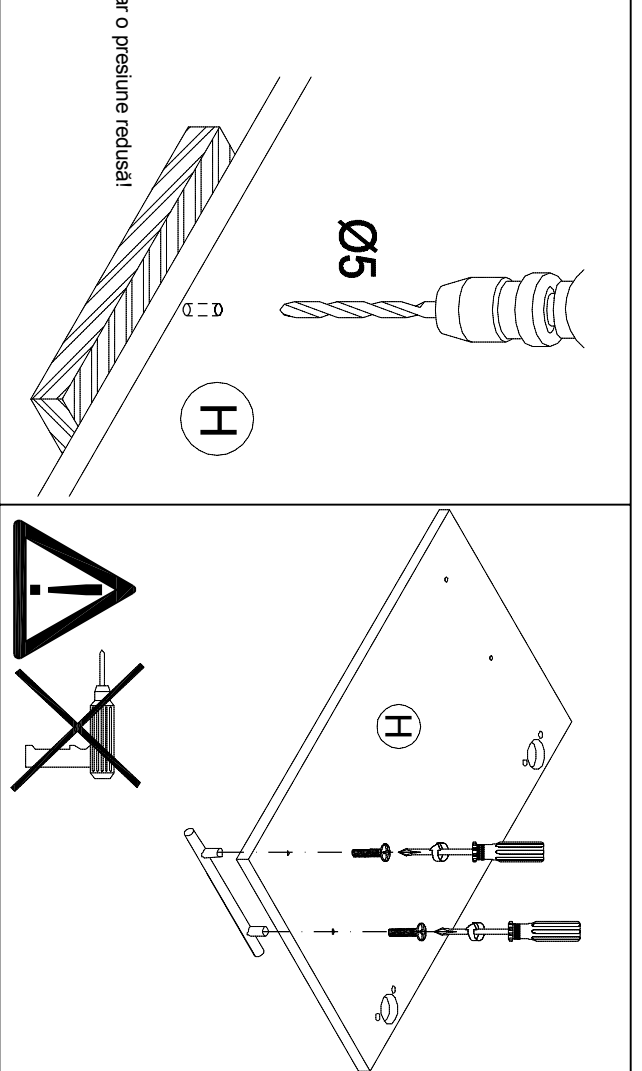
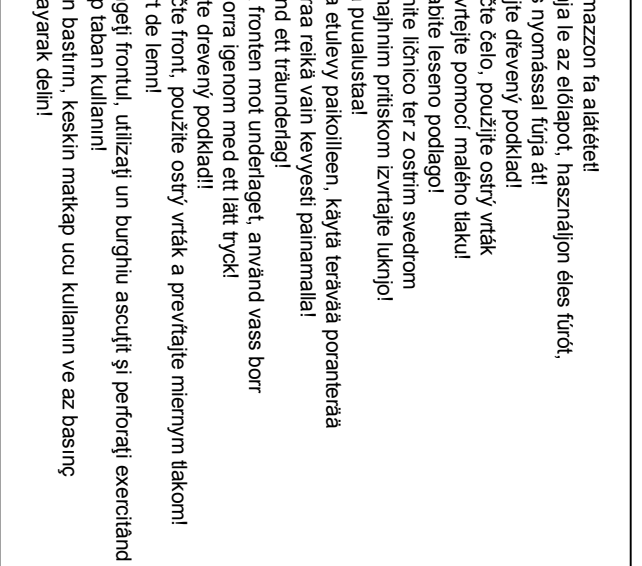
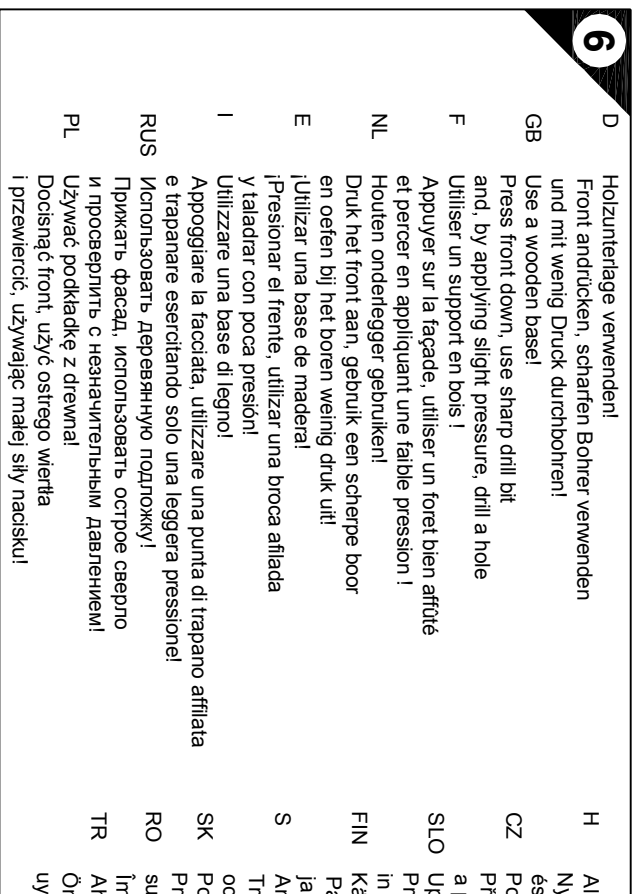
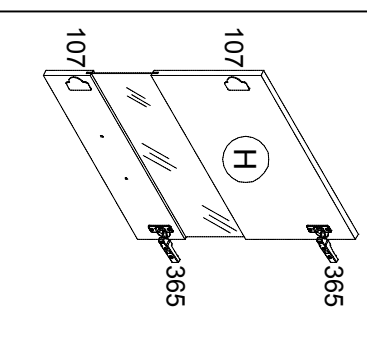

D Holzunterlage verwenden!
Front andrücken, scharfen Bohrer verwenden und mit wenig Druck durchbohren!
Use a wooden base!
Press front down, use sharp drill bit and, by applying slight pressure, drill a hole
Utiliser un support en bois !
Appuyer sur la façade, utiliser un foret bien affûté et percer en appliquant une faible pression !
Utiliser un support en bois !
Houden onderlegger gebruiken!
Druk het front aan, gebruik een scherp boor en oefen bij het boren weinig druk uit!
!Utilizar una base de madera!
!Presionar el frente, utilizar una broca afilada y taladar con poca presión!
Utilizzare una base di legno!
Appoggiare la facciata, utilizzare una punta di trapano affilata e trapanare esercitando solo una leggera pressione!
Использовать деревянную подложку!
Прижать фасад, использовать острое сверло и проворачивать с незначительным давлением!
Używać podkładkę z drewna!
Docisnąć front, użyć ostrygo wiertła i przewiercić, używając małej sily nacisku!

H Alkalmazzon fa alátételt!
Nyomja le az előlapot, hasznájon éles fűrt, és kis nyomással fúrja át!
Použite dřevěný podklad!
Přitlačte čelo, použijte ostrý vrták a prověřte pomocí malého tlaku!
Upravite leseno podlagi!
Pritisnite lico ter z ostrim svetrom in z majhnim pritiskom izvijajte lukrijo!
Käytä puualustaa!
Paina etulevy paikalleen, käytä terävää poranterää ja poraa reikä vain kevyesti painamalla!
Använd ett träunderlag!
Tryck fronten mot underlaget, använd vass borr och borra igenom med ett lätt tryck!
Použite drevený podklad!
Přitlačte front, použijte ostrý vrták a prověřte malým tlakem!
Использовать деревянную подложку!
Прижать фасад, использовать острое сверло и проворачивать с незначительным давлением!
Używać podkładkę z drewna!
Docisnąć front, użyć ostrygo wiertła i przewiercić, używając małej sily nacisku!

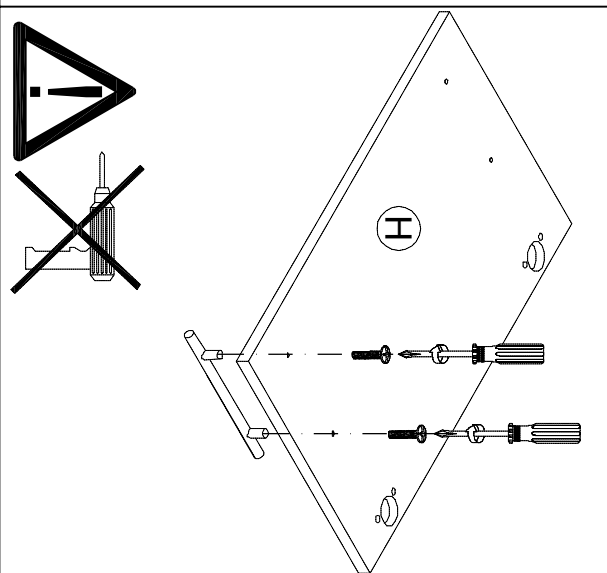
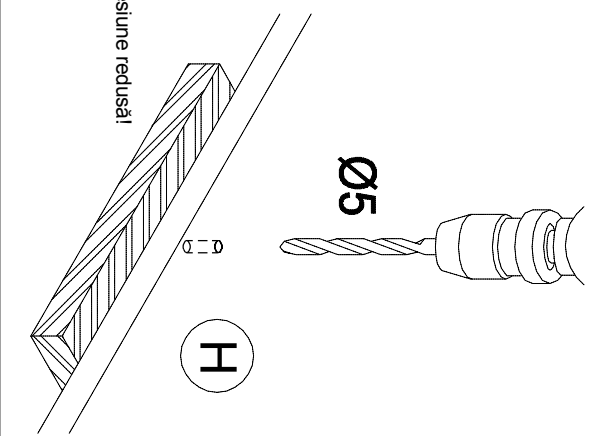

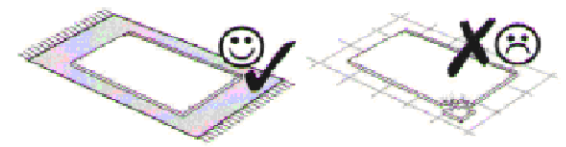
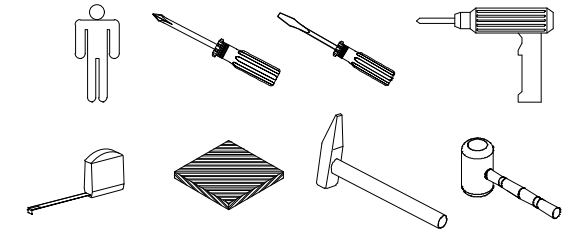

Montageanleitung

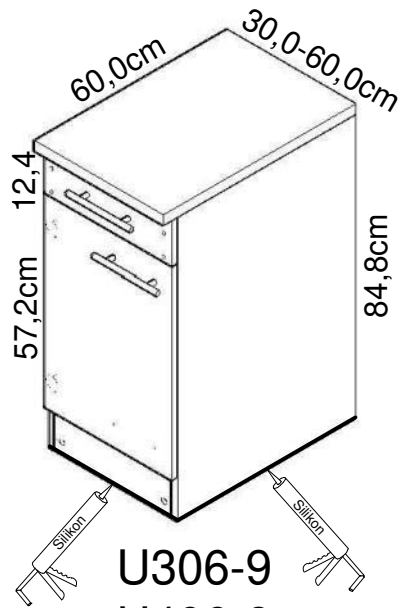

U306-9
U406-9
U506-9
U606-9

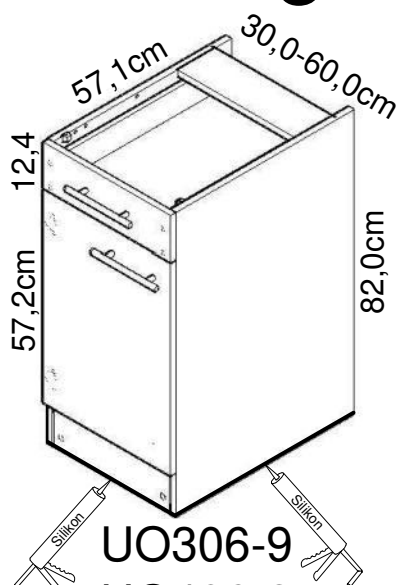

UO306-9
UO406-9
UO506-9
UO606-9

weiß / buche
white / beech
blanc / hêtre
wit / beuken
bianco / haya
bianco / faggio
белый / бук
biały / buk
fehér / bükkfa
bílý / buk
bela / bukev
valkoinen / pyökki
vit / beech
biely / buk
alb / fag
beyaz / kayın

Service-Hotline
01805-678101
0,14€ pro Minute
++49 für Österreich
Auslandstarif pro Minute
service@jaka-bkl.de
voor Nederland en België
00800-40119350
benelux@jaka-bkl.de

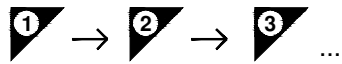
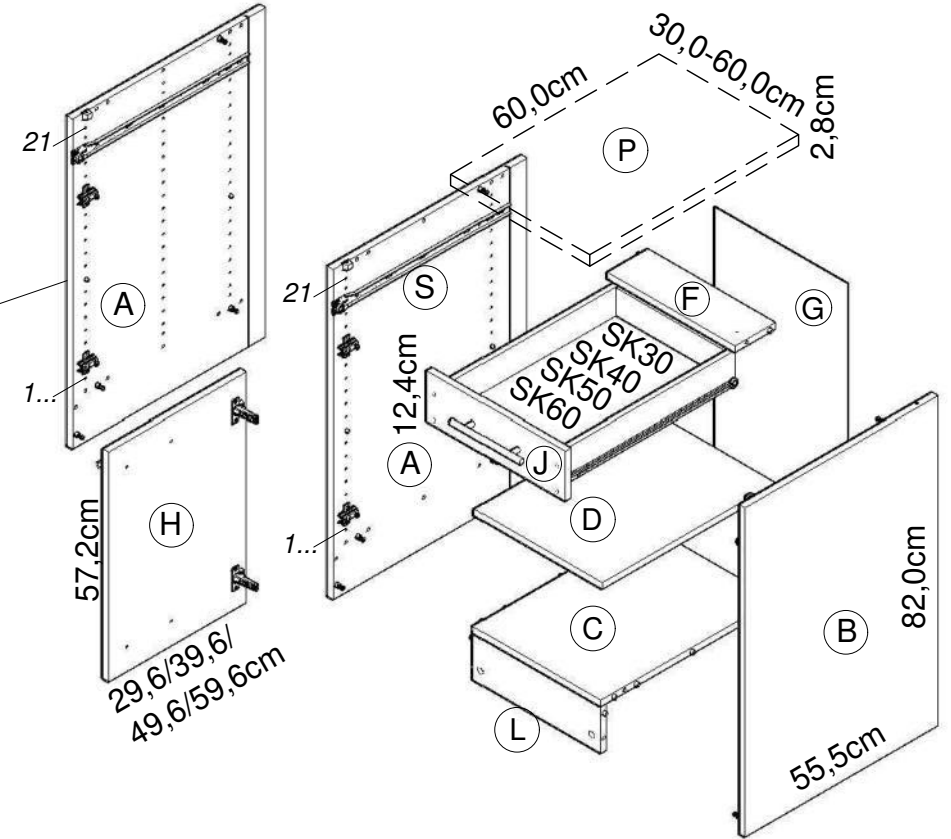

- 1** 8x Nr.98
- 2x Nr.89
- 4x 6,3x12,5 Nr.451
- 2x 4x15 Nr.158
- 2x Nr.367
- 4x Nr.502
- 2** 8x Nr.76
- 14x Ø8x30 Nr.80

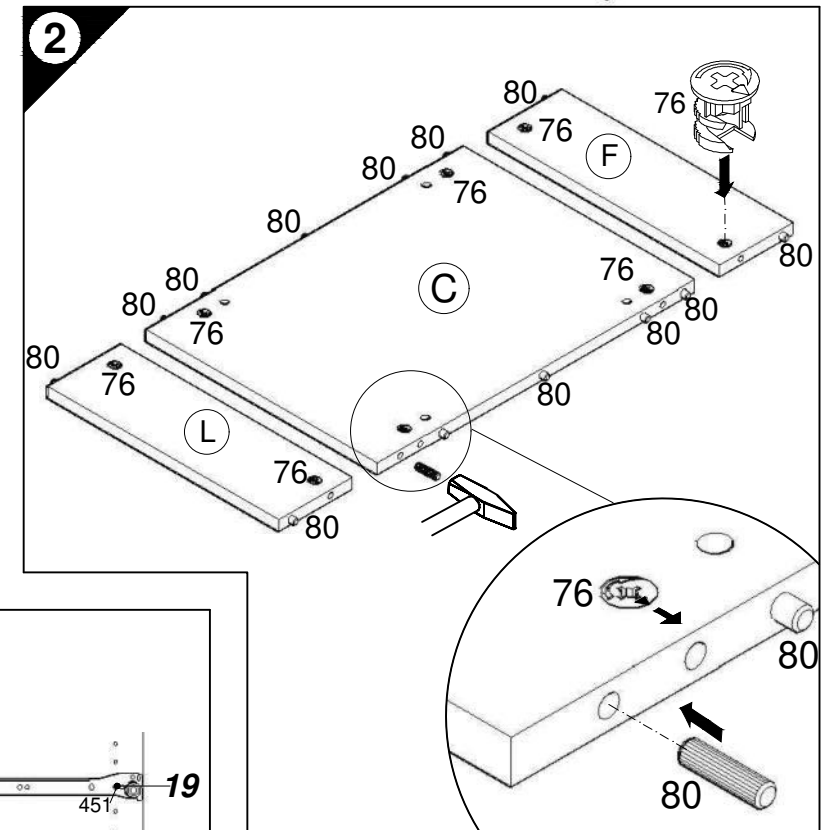
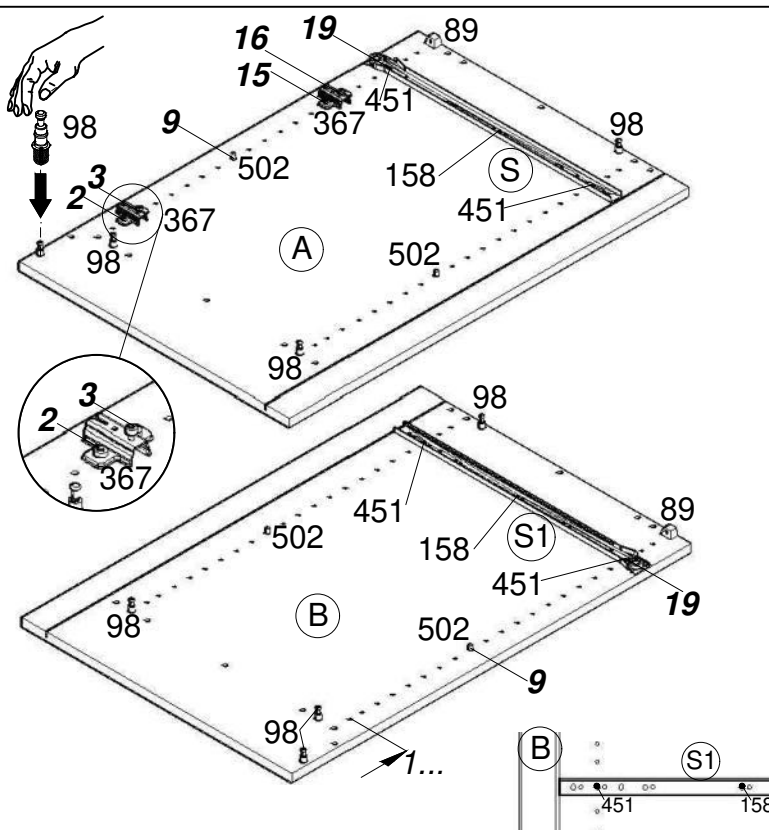
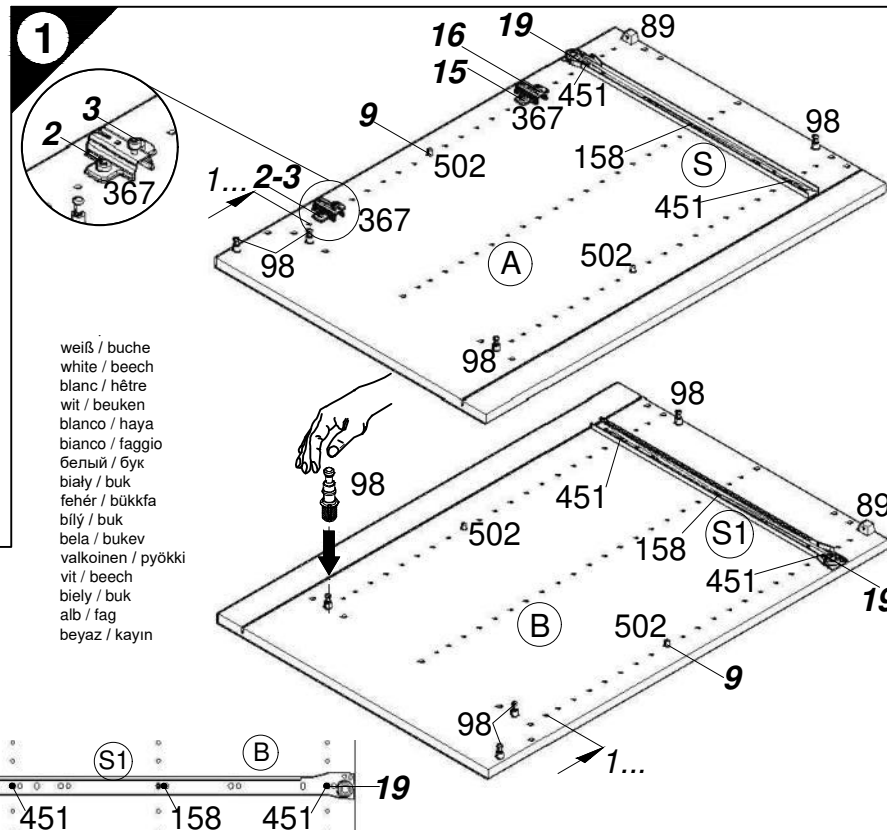

Ersatzteile/Spare parts/pièces de rechange/Reserveonderdelen/Piezas de recambio/Ricambi/Запасные части/Części zamienne/pótalkatrészek/Náhradní části/Nadomestni deli/varaosat/reservdelar/náhradné diely/Utilizați piese de schimb/Yedek parçalar

30cm U(O)306-9 weiß/buche white/beech.....	(A) E961021	(B) E961022	(C) E954216	(D) E950306	(F) E970976	(G) E970006	(H) E940614	(J) E940565	(L) E970976	(P) E540106	(S) E946155	(S1) E946155
40cm U(O)406-9 weiß/buche white/beech.....	(A) E961021	(B) E961022	(C) E954215	(D) E950305	(F) E970975	(G) E970010	(H) E940613	(J) E940564	(L) E970975	(P) E540105	(S) E946155	(S1) E946155
50cm U(O)506-9 weiß/buche white/beech.....	(A) E961021	(B) E961022	(C) E954224	(D) E950304	(F) E970974	(G) E970117	(H) E940612	(J) E940563	(L) E970974	(P) E540104	(S) E946155	(S1) E946155
60cm U(O)606-9 weiß/buche white/beech.....	(A) E961021	(B) E961022	(C) E954223	(D) E950303	(F) E970973	(G) E970116	(H) E940611	(J) E940562	(L) E970973	(P) E540103	(S) E946155	(S1) E946155

1 → 2 → 3 ...

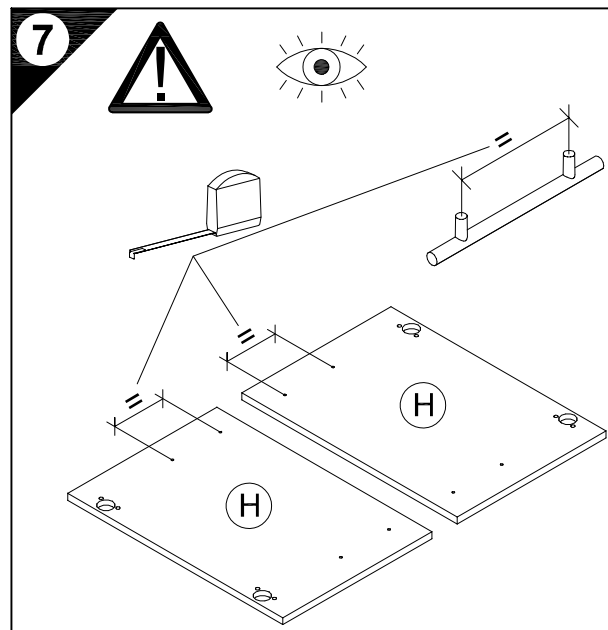
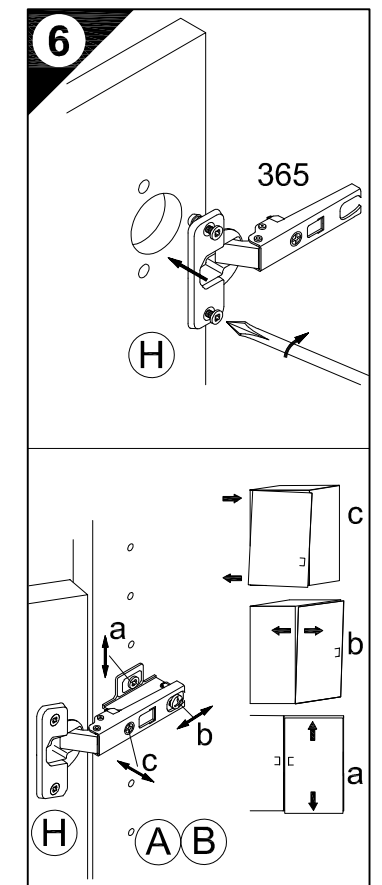
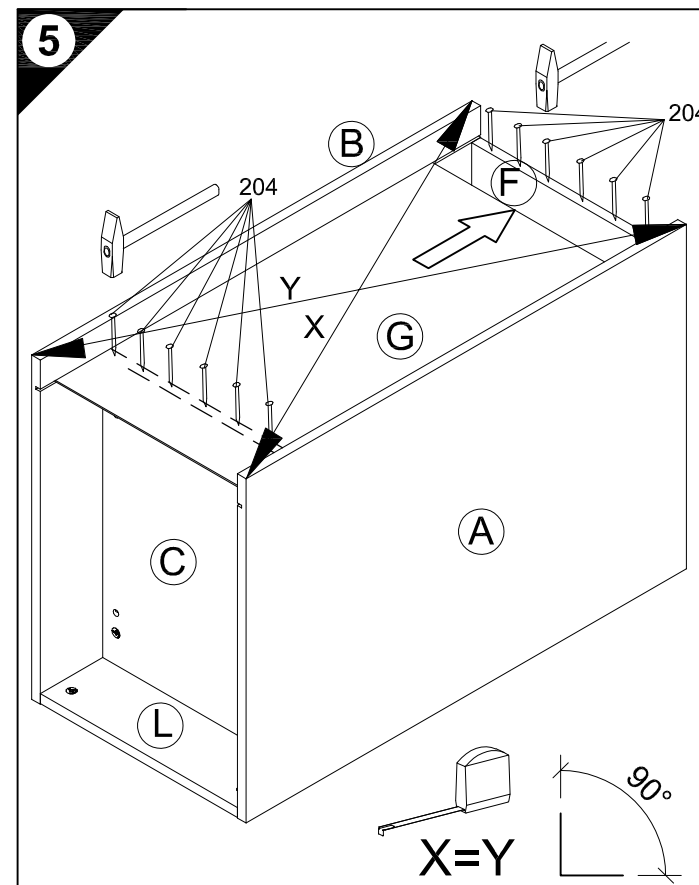
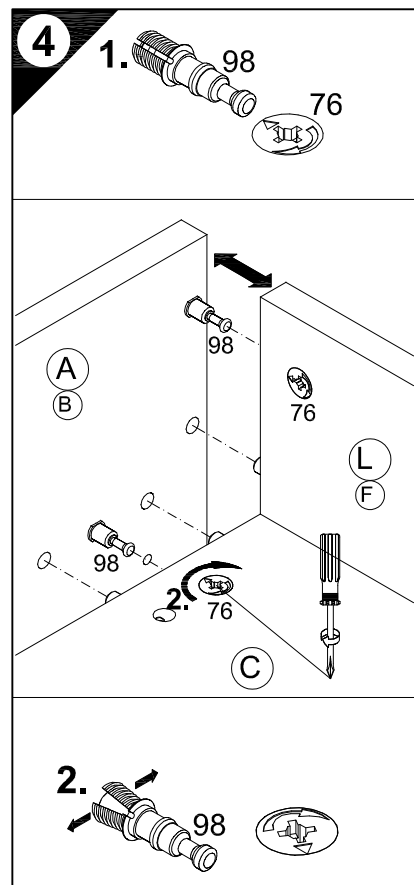
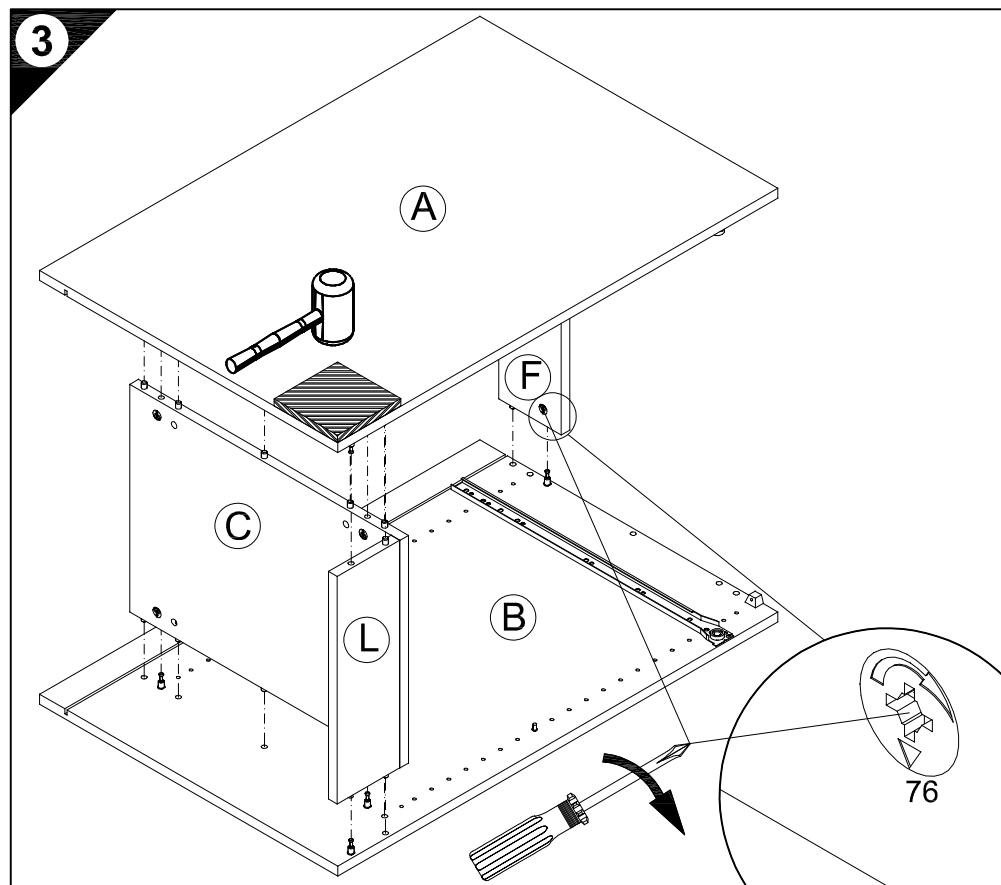
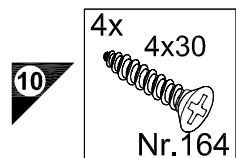
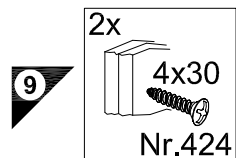
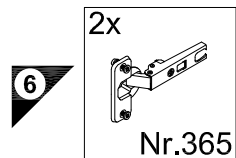
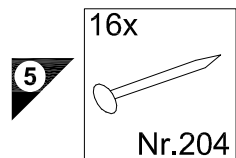

D Holzunterlage verwenden!
Front andrücken, scharfen Bohrer verwenden
und mit wenig Druck durchbohren!

GB Use a wooden base!
Press front down, use sharp drill bit
and, by applying slight pressure, drill a hole
Utiliser un support en bois !
Appuyer sur la façade, utiliser un foret bien affûté
et percer en appliquant une faible pression !

NL Houten onderlegger gebruiken!
Druk het front aan, gebruik een scherpe boor
en oefen bij het boren weinig druk uit!

E ¡Utilizar una base de madera!
¡Presionar el frente, utilizar una broca afilada
y taladrar con poca presión!

I Utilizzare una base di legno!
Appoggiare la facciata, utilizzare una punta di trapano affilata
e trapanare esercitando solo una leggera pressione!

RUS Использовать деревянную подложку!
Прижать фасад, использовать острое сверло
и просверлить с незначительным давлением!

PL Używać podkładkę z drewna!
Docisnąć front, użyć ostrego wiertła
i przewiercić, używając małej siły nacisku!

H Alkalmazzon fa alátétet!
Nyomja le az előlapot, használjon éles fúrót,
és kis nyomással fúrja át!

CZ Použijte dřevěný podklad!
Přitlačte čelo, použijte ostrý vrták
a provrtajte pomocí malého tlaku!

SLO Uporabite leseno podlago!
Pritisnite ličnico ter z ostrim svedrom
in z majhnim pritiskom izvrtajte luknjo!

FIN Käytä puualustaa!
Paina etulevy paikoilleen, käytä terävää poranterää
ja poraa reikä vain kevyesti painamalla!

S Använd ett träunderlag!
Tryck fronten mot underlaget, använd vass borrh
och borra igenom med ett lätt tryck!

SK Použite drevený podklad!!
Přitlačte front, použite ostrý vrták a prevrtajte miernym tlakom!

RO suport de lemn! Împingeți frontul, utilizați un burghiu ascuțit
și perforați exercitând doar o presiune redusă!

TR Ahşap taban kullanın!
Önden bastırın, keskin matkap ucu kullanın ve az basınç
uygulayarak delin!

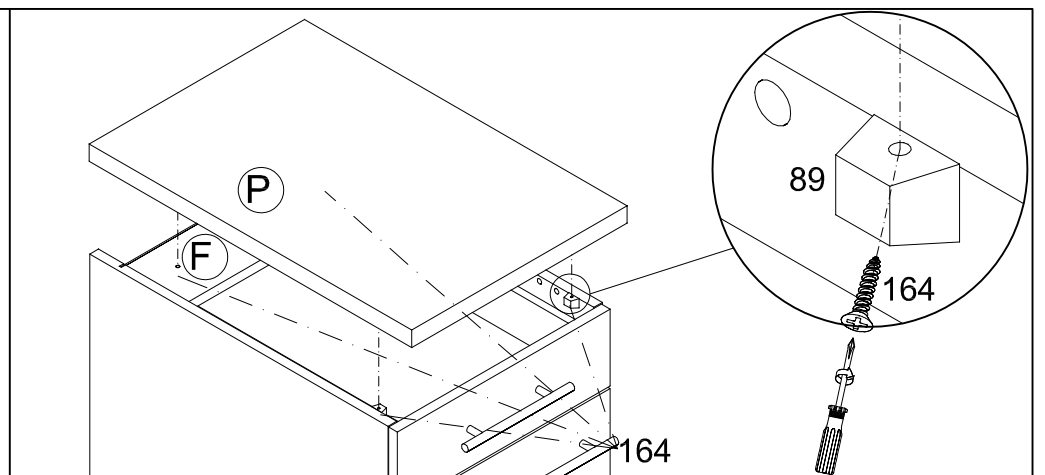
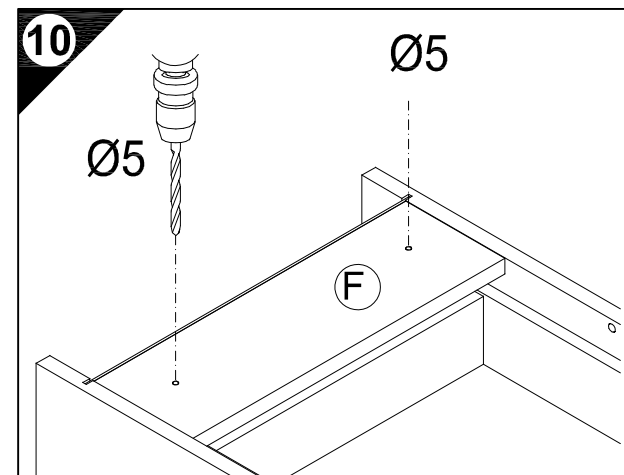
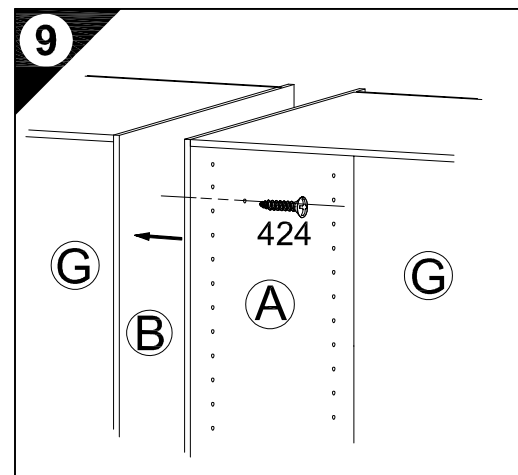
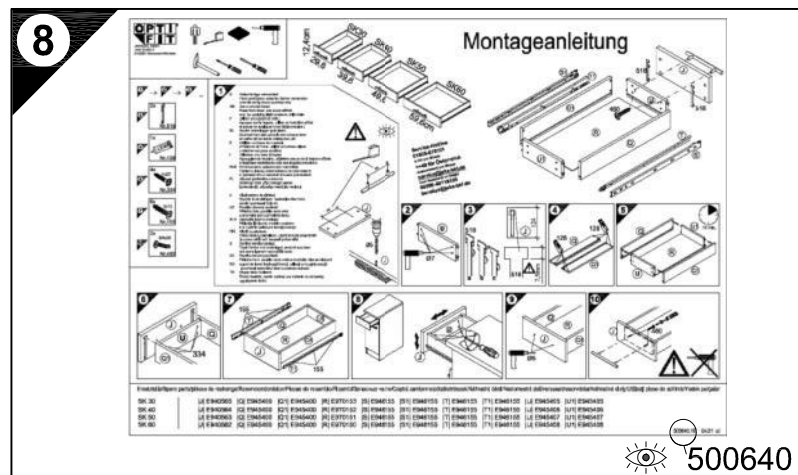
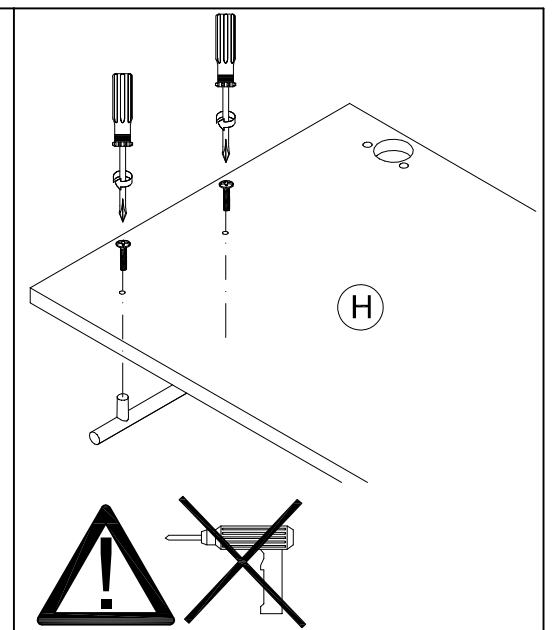
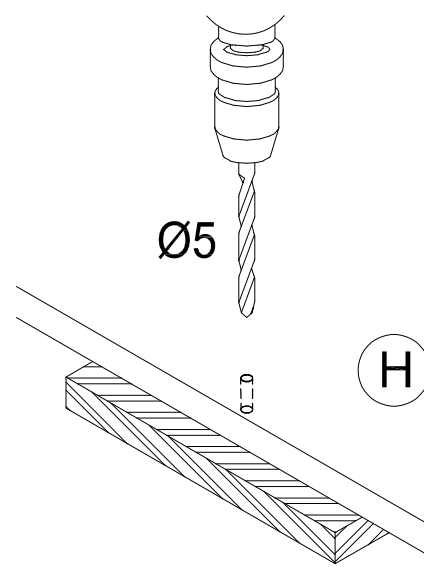

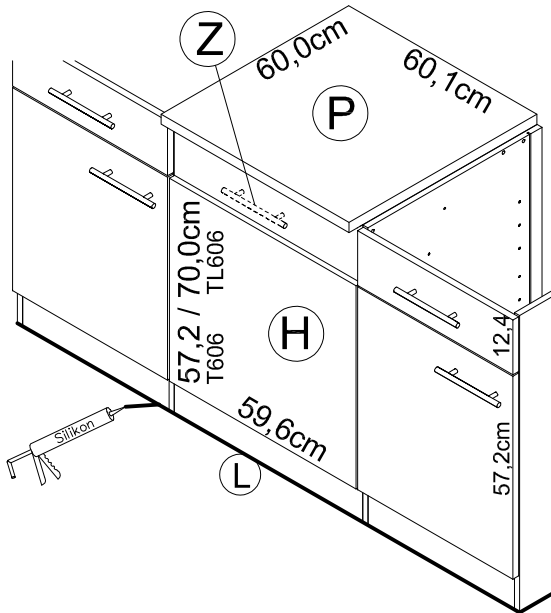
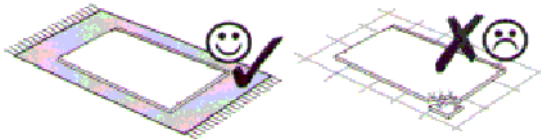
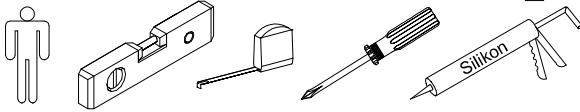

Montageanleitung

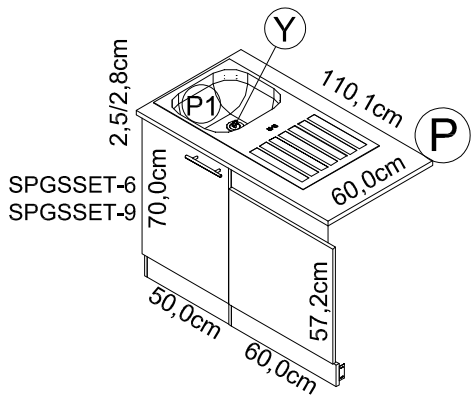
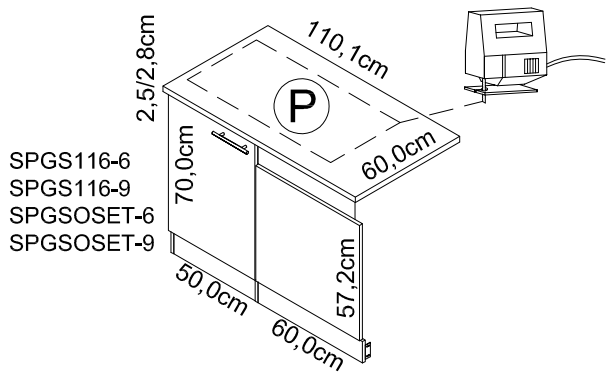
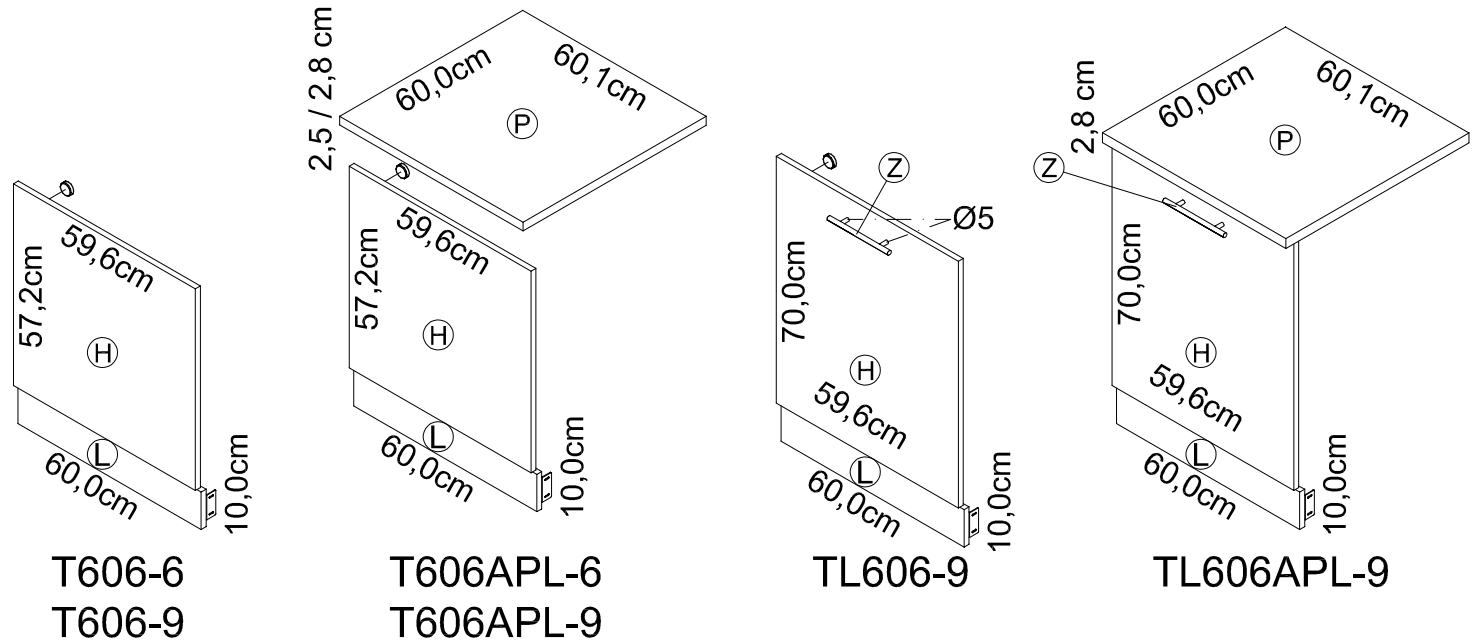

Service-Hotline
01805-678101
0,14€ pro Min.
++49 für Österreich
Auslandstarif pro Min.
service@jaka-bkl.de
voor Nederland en België
00800-40119350
benelux@jaka-bkl.de

Ersatzteile/Spare parts/pièces de rechange/Reserveonderdelen/Piezas de recambio/Ricambi/Запасные части/Części zamienne/półtaktrészek/Náhradní části/Nadomestni deli/varaosat/reservdelar/náhradné diely/Utilizați piese de schimb/Yedek parçalar

T 606-6	H E980611	L E946060	TL 606-9	H E940621	L E946060	Z E447100
T 606-9	H E940611	L E946060	TL 606APL-9	H E940621	L E946060	P E540103 Z E447100
T 606APL-6	H E980611	L E946060	SPGS...-6	P E441100	P1 E448292	Y E446500
T 606APL-9	H E940611	L E946060	SPGS...-9	P E540100	P1 E448292	Y E446500

1 → 2 → 3 ...

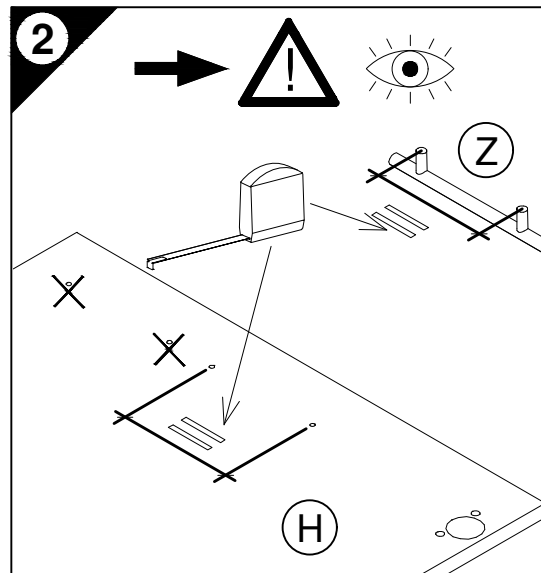
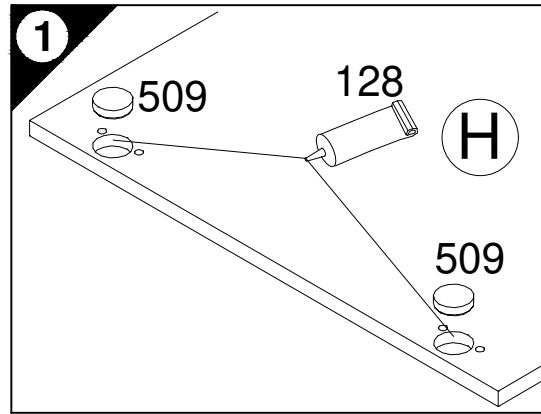
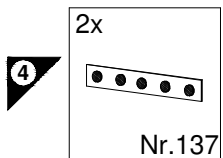
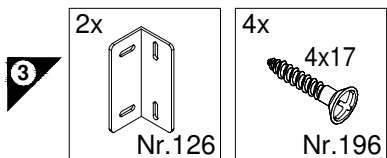
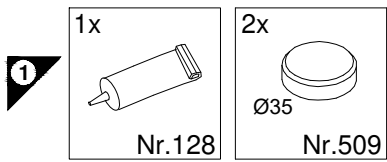

- D Holzunterlage verwenden!
Front andrücken, scharfen Bohrer verwenden und mit wenig Druck durchbohren!
- GB Use a wooden base!
Press front down, use sharp drill bit and, by applying slight pressure, drill a hole
- F Utiliser un support en bois !
Appuyer sur la façade, utiliser un foret bien affûté et percer en appliquant une faible pression !
- NL Houten onderlegger gebruiken!
Druk het front aan, gebruik een scherpe boor en oefen bij het boren weinig druk uit!
- E ¡Utilizar una base de madera!
¡Presionar el frente, utilizar una broca afilada y taladrar con poca presión!
- I Utilizzare una base di legno! Appoggiare la facciata, utilizzare una punta di trapano affilata e trapanare esercitando solo una leggera pressione!
- RUS Использовать деревянную подложку!
Прижать фасад, использовать острое сверло и просверлить с незначительным давлением!
- PL Używać podkładkę z drewna!
Docisnąć front, użyć ostrego wiertła i przewiercić, używając małej siły nacisku!
- H Alkalmazzon fa alátét!
Nyomja le az előlapot, használjon éles fúrót, és kis nyomással fúrja át!
- CZ Použijte dřevěný podklad!
Přitlačte čelo, použijte ostrý vrták a prověřte pomocí malého tlaku!
- SLO Uporabite leseno podlago!
Pritisnite ličnico ter z ostrim svedrom in z majhnim pritiskom izvrtajte luknjo!
- FIN Käytä puualustaa!
Paina etulevy paikoilleen, käytä terävää poranterää ja poraa reikä vain kevyesti painamalla!
- S Använd ett träunderlag!
Tryck fronten mot underlaget, använd vass borr och borra igenom med ett lätt tryck!
- SK Použite drevený podklad!!
Pritlačte front, použite ostrý vrták a prevrtajte miernym tlakom!
- RO suport de lemn! Împingeți frontul, utilizați un burghiu ascuțit și perforați exercitând doar o presiune redusă!
- TR Ahşap taban kullanın!
Önden bastırın, keskin matkap ucu kullanın ve az basınç uygulayarak delin!

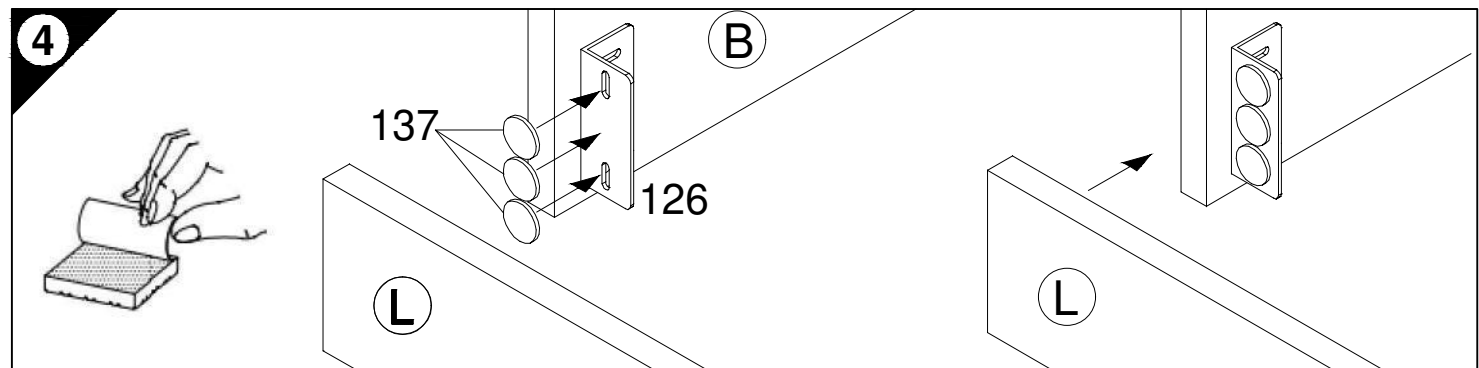
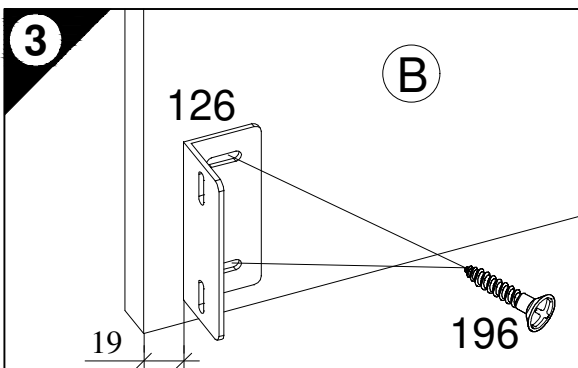
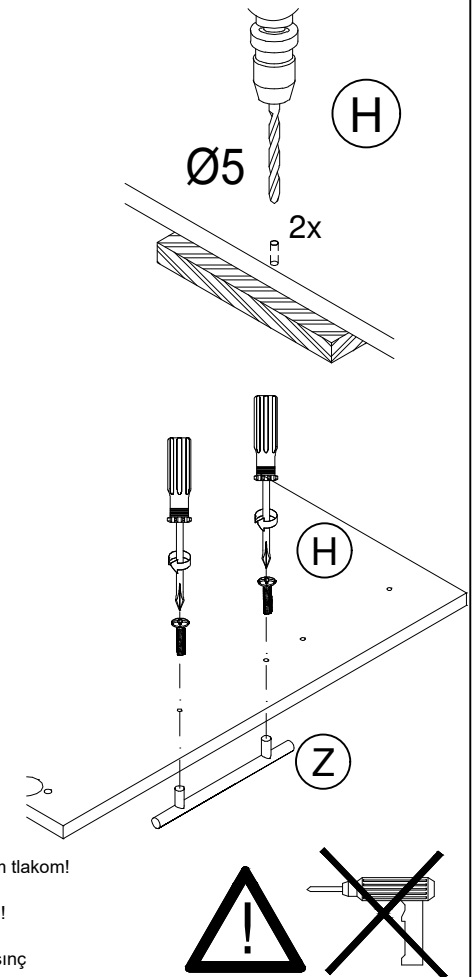

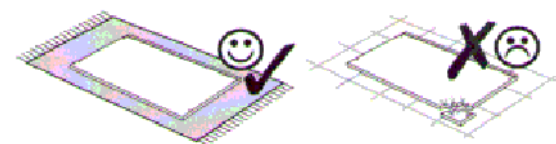
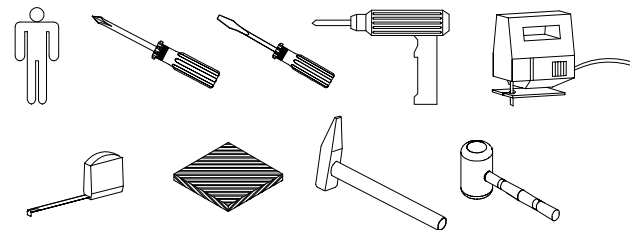

Montageanleitung

SPGS116-9
SPGS116-6
SPGSOSET-9
SPGSOSET-6

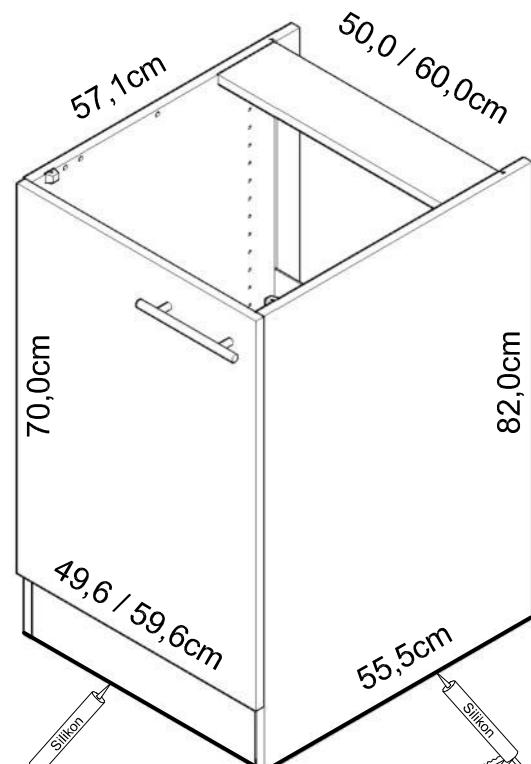
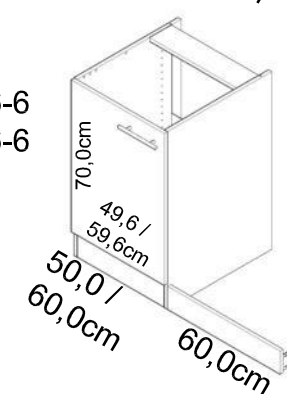
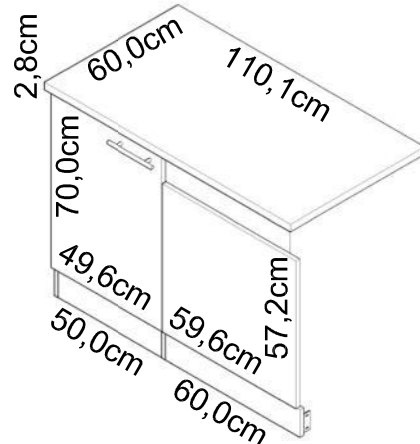

SPLO506-6 / -9
SPLO606-6 / -9

weiß / buche
white / beech
blanc / hêtre
wit / beuken
blanco / haya
bianco / faggio
белый / бук
biały / buk
fehér / bükkfa
bílý / buk
bela / bukev
valkoinen / pyökki
vit / beech
blely / buk
alb / fag
beyaz / kayın

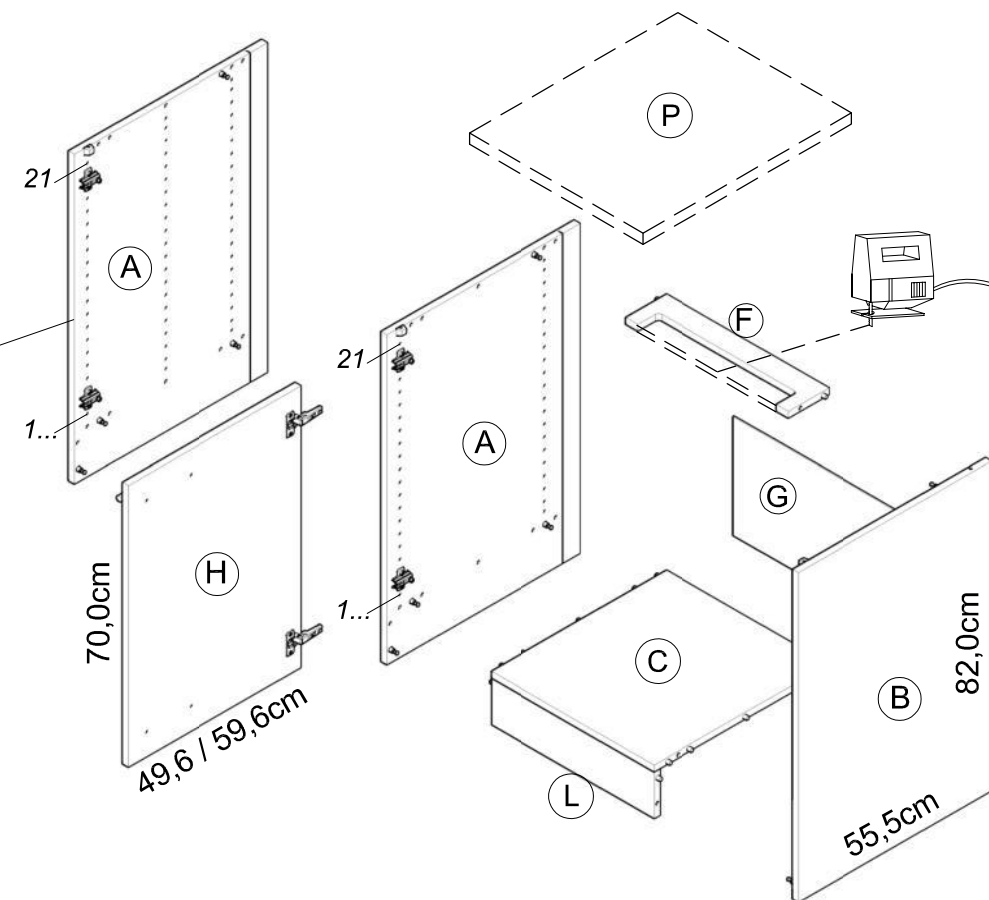

1 → 2 → 3 ...

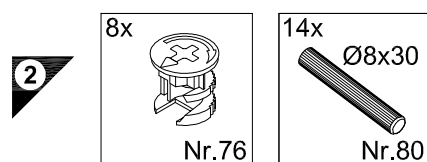
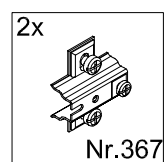
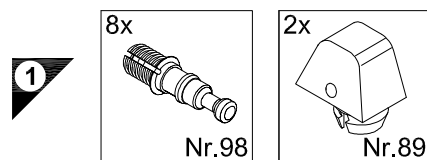

VSPTO506-6
VSPTO606-6

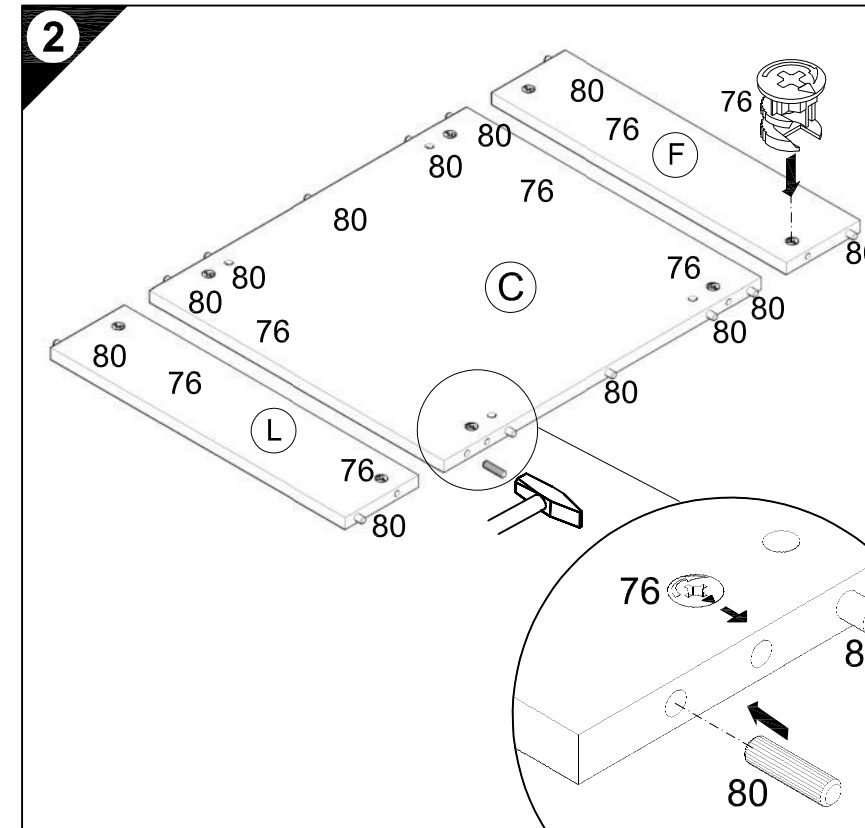
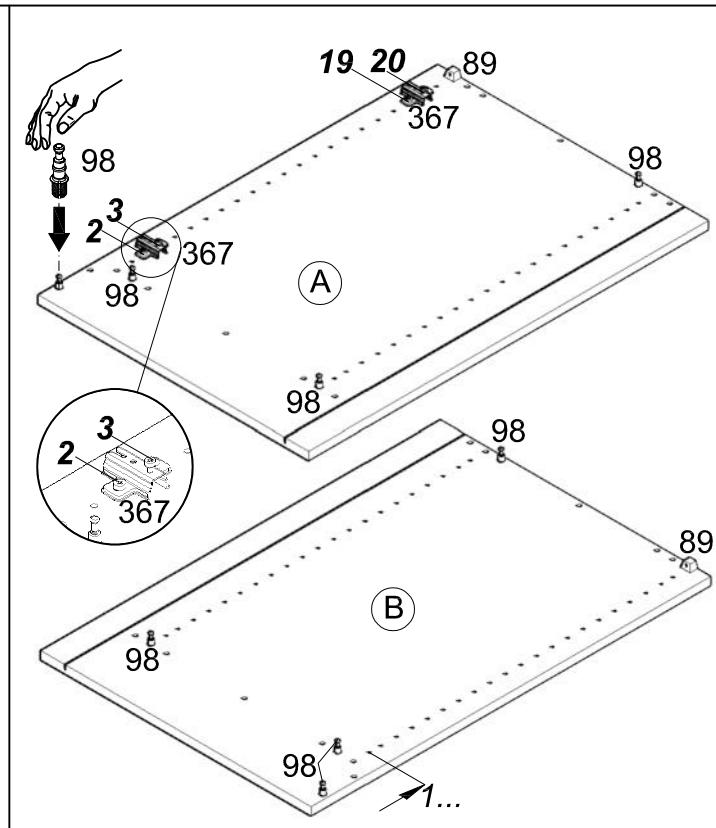
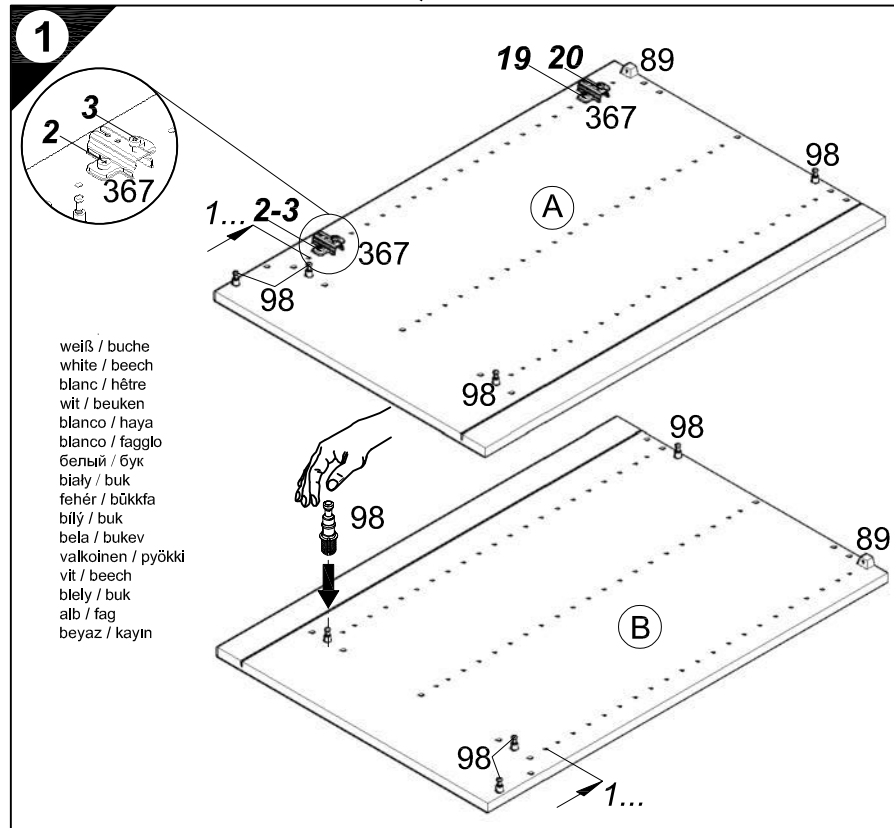

Service-Hotline
01805-678101
0,14€ pro Minute
++49 für Österreich
Auslandstarif pro Minute
service@jaka-bkl.de
voor Nederland en België
00800-40119350
benelux@jaka-bkl.de

weiß / buche
white / beech
blanc / hêtre
wit / beuken
blanco / haya
bianco / faggio
белый / бук
biały / buk
fehér / bükkfa
bílý / buk
bela / bukev
valkoinen / pyökki
vit / beech
blely / buk
alb / fag
beyaz / kayın

Ersatzteile/Spare parts/pièces de rechange/Reserveonderdelen/Piezas de recambio/Ricambi/Запасные части/Części zamienne/pótalkatrészek/Náhradní části/Nadomestni deli/varaosat/reservdelar/náhradné diely/Utilizați piese de schimb/Yedek parçalar

50cm SPLO506-9 / -6	A E961021	B E961022	C E954224	F E970974	G E445043	H E940622	L E970974
weiß/buche SPLO506-9 / -6	A E981021	B E981022	C E954224	F E970974	G E445043	H E940622	L E970974
white/beech.....							
60cm SPLO606-9 / -6	A E961021	B E961022	C E954223	F E970973	G E970079	H E940621	L E970973
weiß/buche SPLO606-9 / -6	A E981021	B E981022	C E954223	F E970973	G E970079	H E940621	L E970973
white/beech.....							

1 → 2 → 3 ...

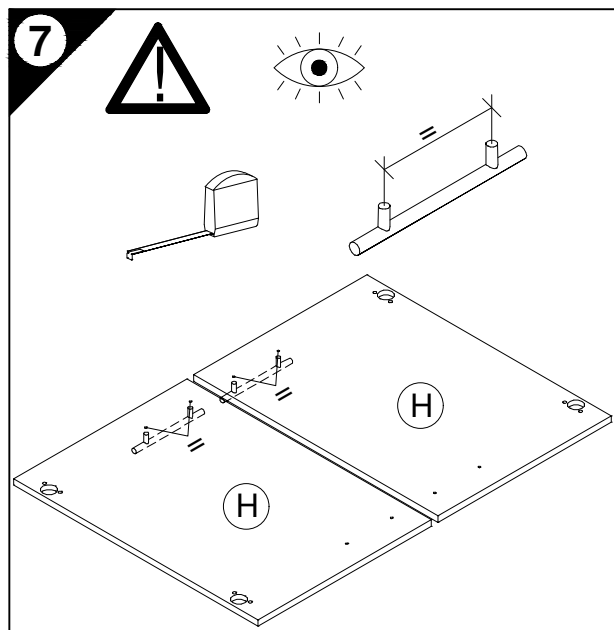
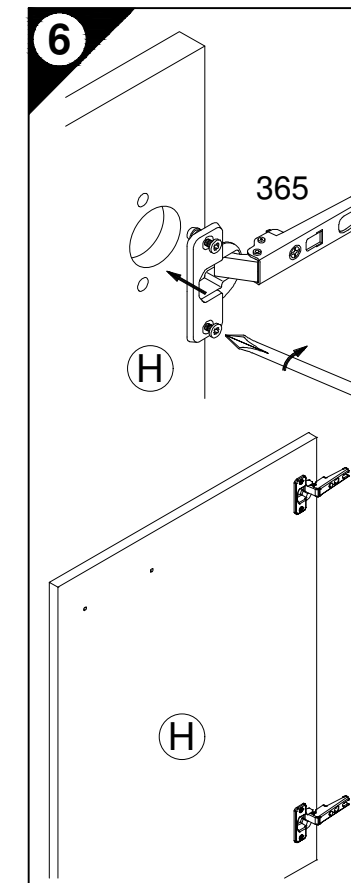
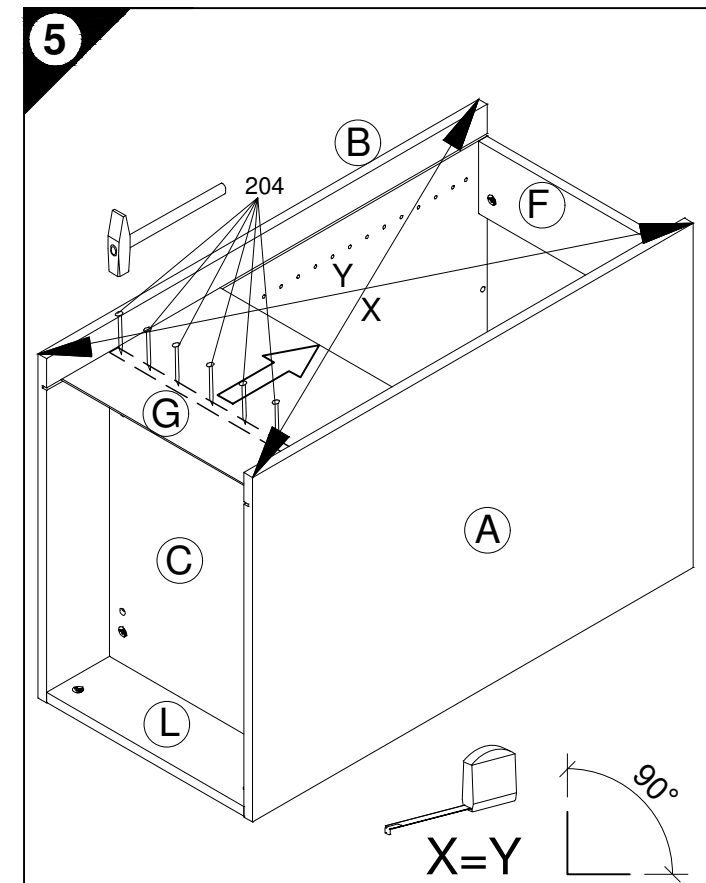
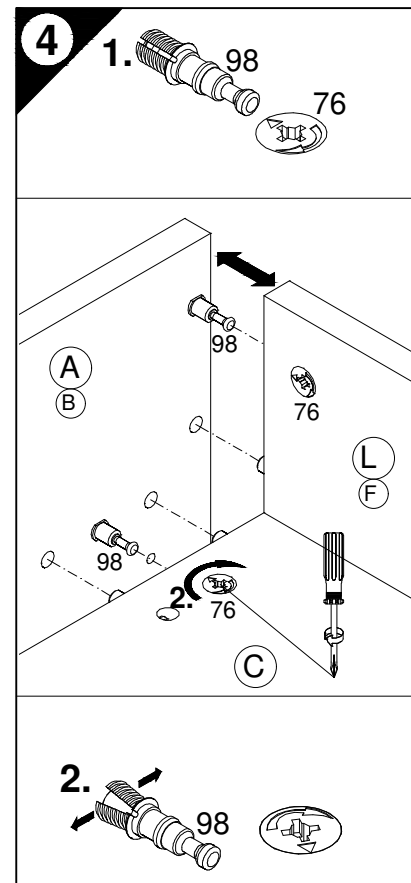
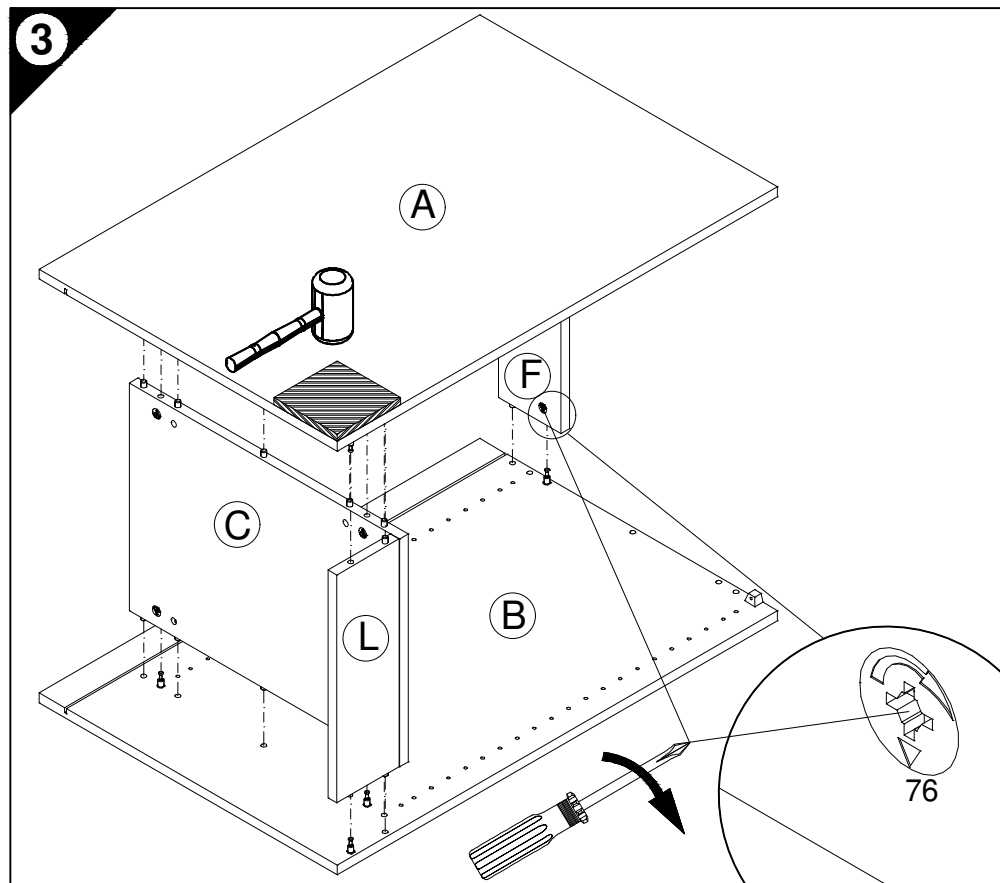
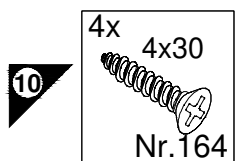
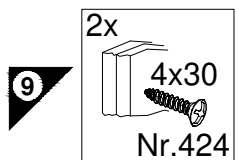
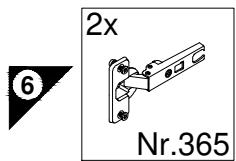
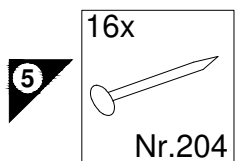

D Holzunterlage verwenden!
Front andrücken, scharfen Bohrer verwenden
und mit wenig Druck durchbohren!

GB Use a wooden base!
Press front down, use sharp drill bit
and, by applying slight pressure, drill a hole

F Utiliser un support en bois !
Appuyer sur la façade, utiliser un foret bien affûté
et percer en appliquant une faible pression !

NL Houten onderlegger gebruiken!
Druk het front aan, gebruik een scherpe boor
en oefen bij het boren weinig druk uit!

E ¡Utilizar una base de madera!
¡Presionar el frente, utilizar una broca afilada
y taladrar con poca presión!

I Appoggiare la facciata, utilizzare una punta di trapano affilata
e trapanare esercitando solo una leggera pressione!

RUS Использовать деревянную подложку!
Прижать фасад, использовать острое сверло
и просверлить с незначительным давлением!

PL Używać podkładkę z drewna!
Docisnąć front, użyć ostrego wiertła
i przewiercić, używając małej siły nacisku!

H Alkalmazzon fa alátétet!
Nyomja le az előlapot, használjon éles fúrót,
és kis nyomással fúrja át!

CZ Použijte dřevěný podklad!
Přitlačte čelo, použijte ostrý vrták
a provrtějte pomocí malého tlaku!

SLO Uporabite leseno podlago!
Pritisnite ličnico ter z ostrim svedrom
in z majhnim pritiskom izvrtajte luknjo!

FIN Käytä puualustaa!
Paina etulevy paikoilleen, käytä terävää poranterää
ja poraa reikä vain kevyesti painamalla!

S Använd ett träunderlag!
Tryck fronten mot underlaget, använd vass borrh
och borra igenom med ett lätt tryck!

SK Použite drevený podklad!
Pritlačte front, použite ostrý vrták a prevrtajte miernym tlakom!

RO suport de lemn! Împingeți frontul, utilizați un burghiu ascuțit
și perforați exercitând doar o presiune redusă!

TR Ahşap taban kullanın!
Önden bastırın, keskin matkap ucu kullanın ve az basınç
uygulayarak delin!

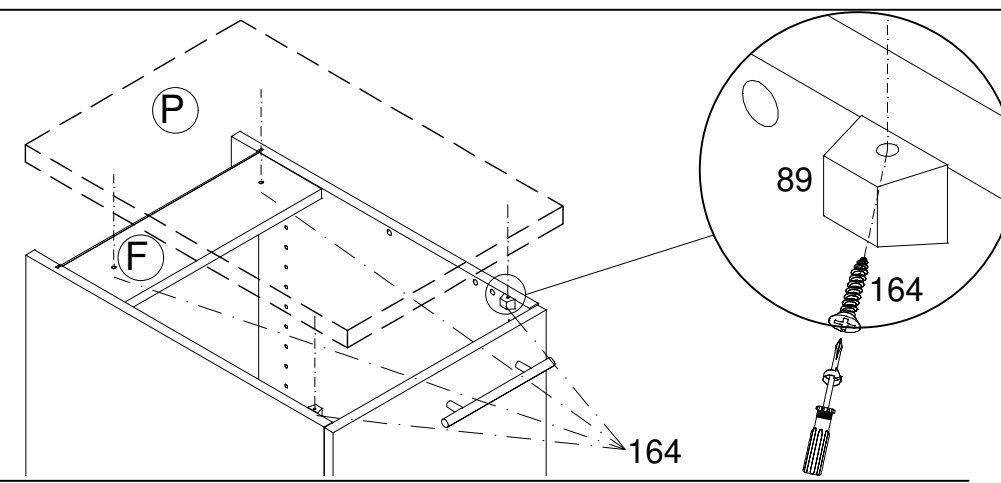
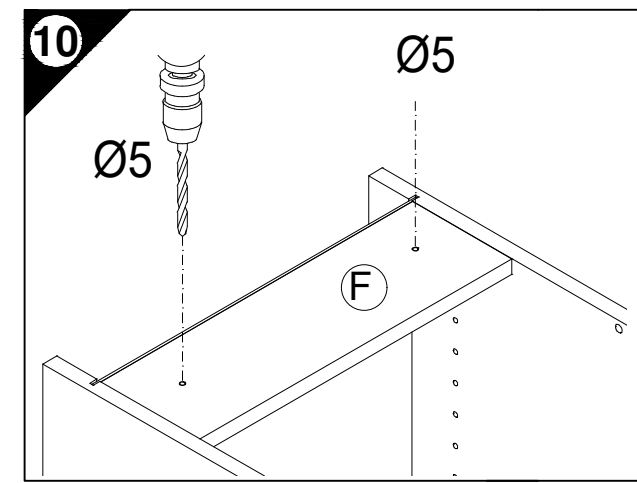
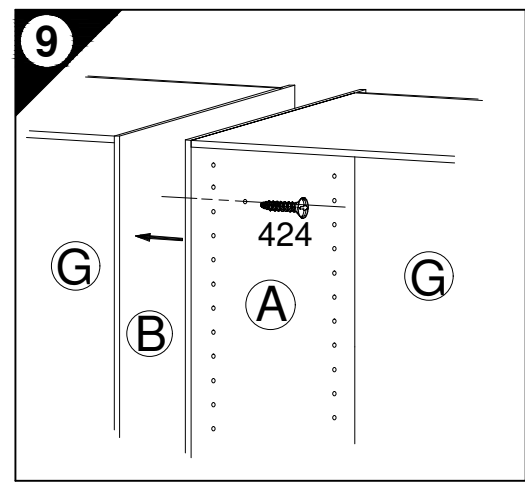
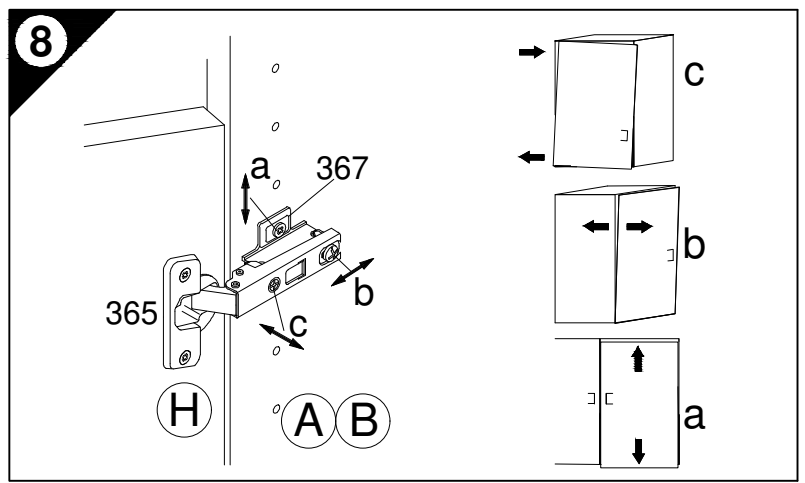
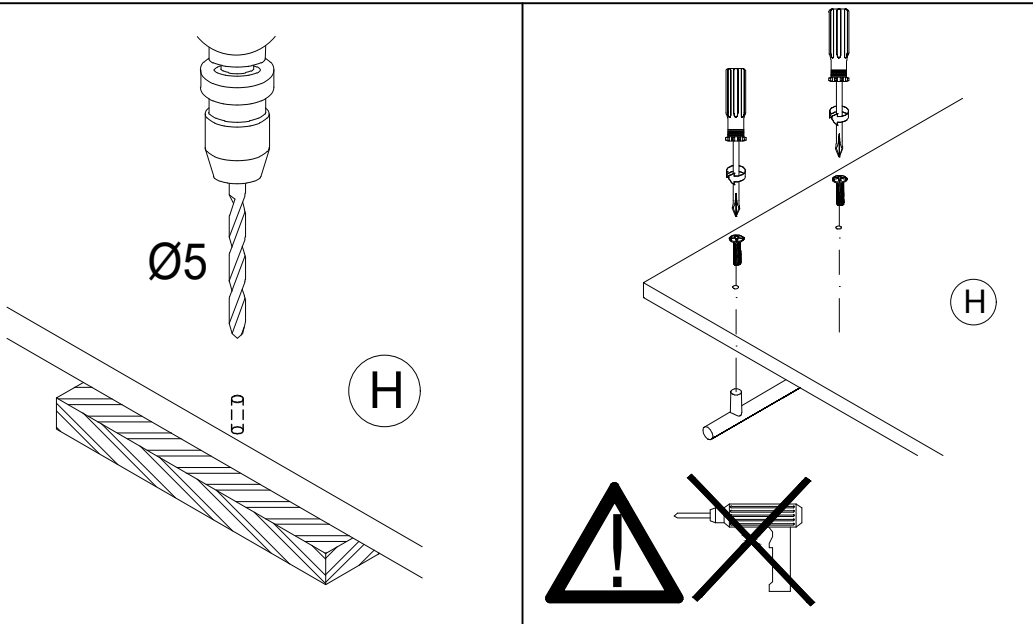

1 → 2 → 3 ...

- 4 2x 6,3x13
Nr.274
- 5 8x
Nr.536
- 6 3x 4x30
Nr.424
- 7 1x Nr.214 2x 4,5x15
Nr.191
- 1x Ø8 1x 4,5x45
Nr.70 Nr.175
- 9 2x
Nr.365
- 10 4x 4x30
Nr.164

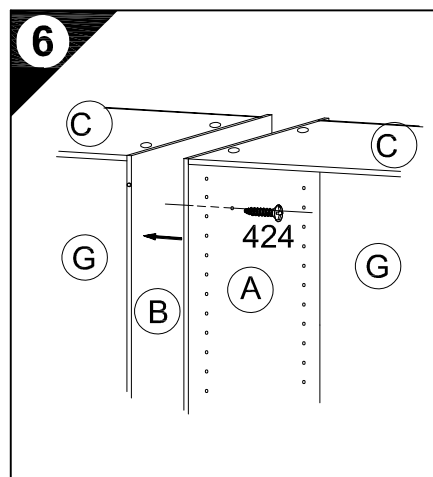
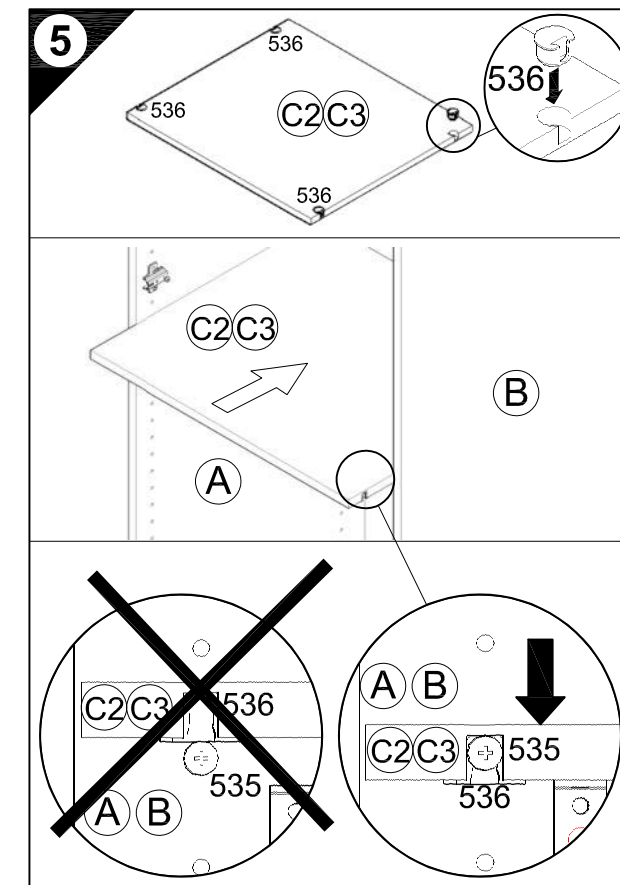
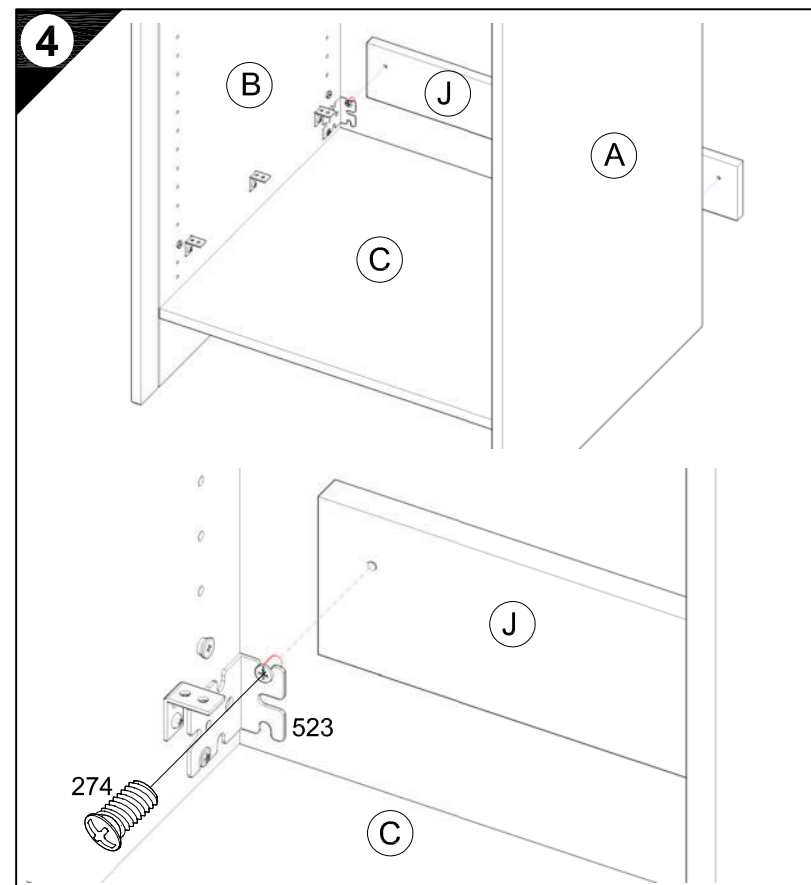
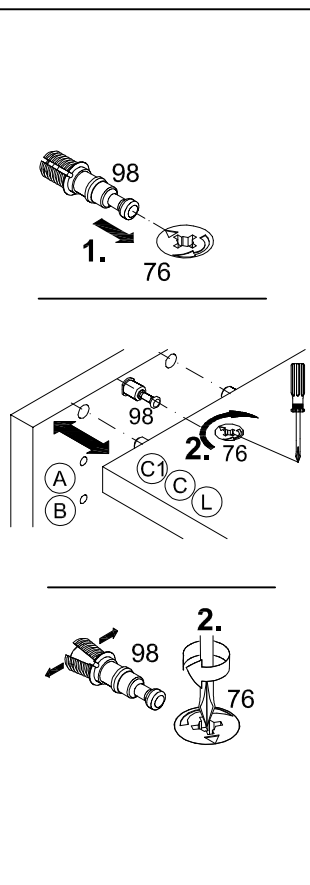
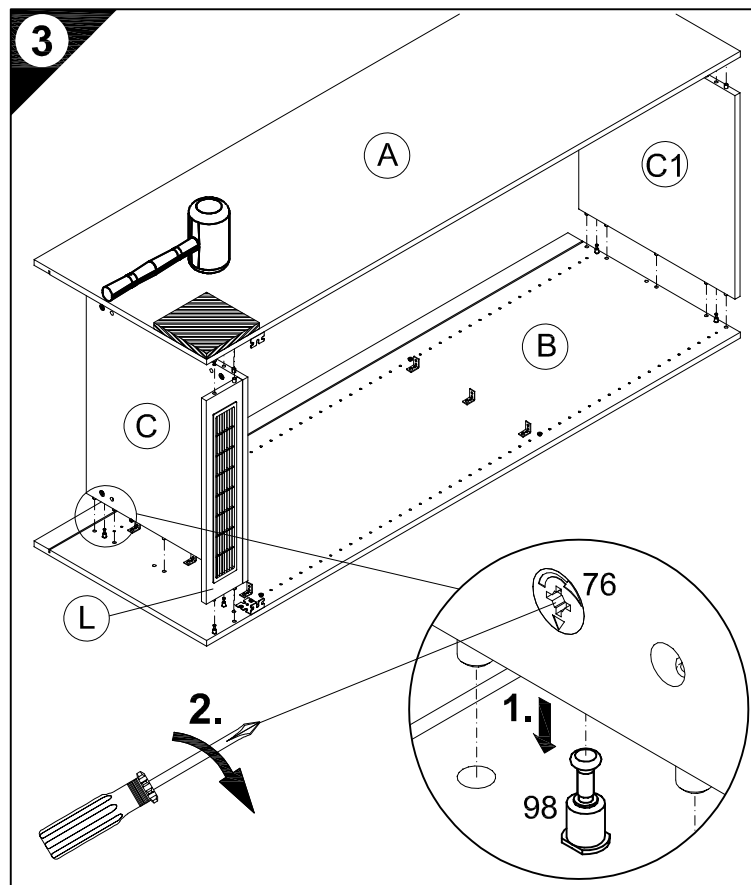

7

D Wandbefestigung zwingend erforderlich!
 GB Wall fixing essential!
 F A fixer impérativement au mur!
 NL Wandbevestiging dringend vereist!
 E ¡Fijación en la pared absolutamente necesaria!
 I Il fissaggio alla parete è indispensabile!
 RUS Крепление к стене обязательно!
 PL Mocowanie do sciany bezwzględnie konieczne!
 H A falra törtendő rögzítésre feltétlenül szükség van!
 CZ Nástěnná montáž nezbytně nutná!
 SLO Obvezna je pritrđitev na steno!
 FIN Kiinnitettävä ehdottomasti seinään!
 S Ett väggfäste är absolut nödvändigt!
 SK Nutná montáž na stenu!
 RO Fixarea la perete este neapărat necesară!
 TR Duvara sabitlenmesi kesinlikle gerekir!

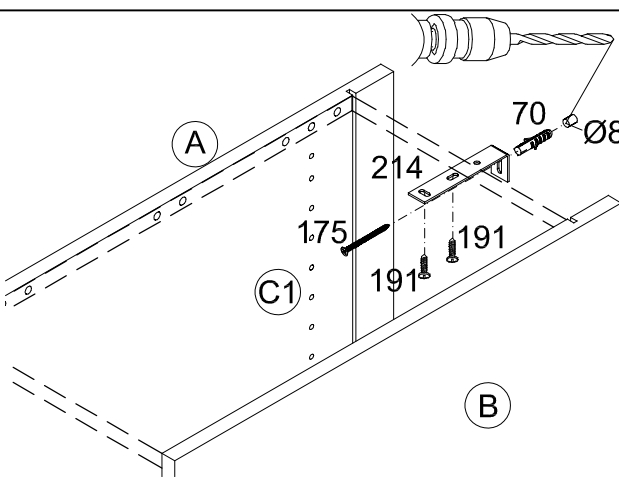

D Untergrund und Befestigungsmittel auf Eignung prüfen!
 GB Check substructure and fixings for suitability!
 F Contrôler si le support et les moyens de fixation sont bien adéquats !
 NL Ondergrond en bevestigingsmateriaal op functionaliteit controleren!
 E ¡Comprobar el suelo y los medios de fijación en cuanto a su aptitud!
 I Controllare l'idoneità del fondo e del materiale di fissaggio!
 RUS Основание и крепежный материал проверить на пригодность!
 PL Podłoże oraz materiały do zamocowania sprawdzić na ich przydatność!
 H Az alapelületet és a rögzítő anyagokat megfelelőség szempontjából ellenőrizni kell!
 CZ Přezkoušejte podklad a vhodnost upevňovacích prostředků!
 SLO Preverite, če se ujemajo spodnja stran in pritrđilna sredstva!
 FIN Tarkista alustan ja kiinnitysvälineiden sopivuus!
 S Kontrollera att underlaget och fästmedlen är lämpliga!
 SK Preverte vhodnosť podkladu a upevňovacích prostriedkov!
 RO Verificați caracterul adecvat al suprafeței suport și al mijloacelor de fixare!
 TR Zemin ve bağlanı elemanlarının uygunluğunu kontrol edin!

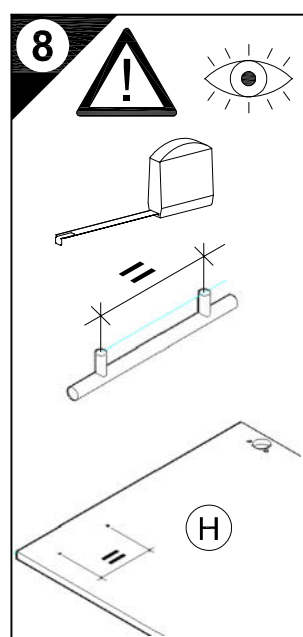

8

D Holzunterlage verwenden!
 Front andrücken, scharfen Bohrer verwenden und mit wenig Druck durchbohren!
 GB Use a wooden base!
 Press front down, use sharp drill bit and, by applying slight pressure, drill a hole
 F Utiliser un support en bois !
 Appuyer sur la façade, utiliser un foret bien affûté et percer en appliquant une faible pression !
 NL Houten onderlegger gebruiken!
 Druk het front aan, gebruik een scherpe boor en oefen bij het boren weinig druk uit!
 E ¡Utilizar una base de madera!
 ¡Presionar el frente, utilizar una broca afilada y taladrar con poca presión!
 I Utilizzare una base di legno! Appoggiare la facciata, utilizzare una punta di trapano affilata e trapanare esercitando solo una leggera pressione!
 RUS Использовать деревянную подложку!
 Прижать фасад, использовать острое сверло и просверлить с незначительным давлением!
 PL Używać podkładkę z drewna!
 Docisnąć front, użyć ostrego wiertła i przewiercić, używając małej siły nacisku!

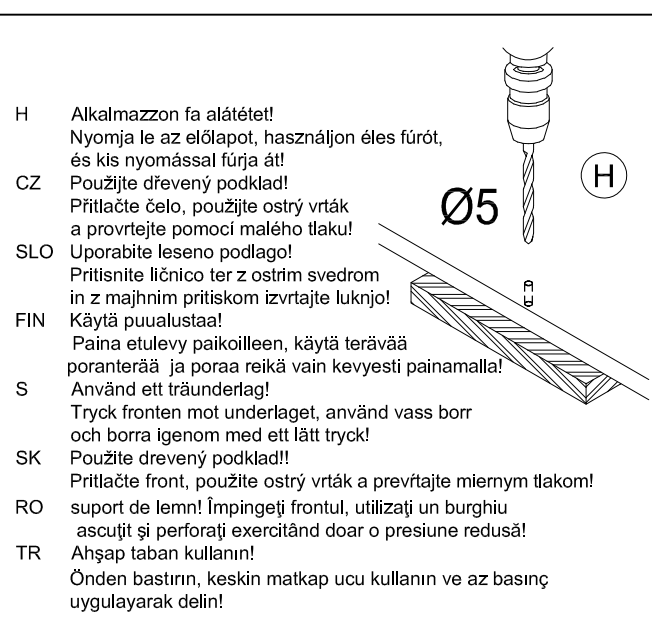

9

H Alkalmazzon fa alátétet!
 Nyomja le az előlapot, használjon éles fúrót, és kis nyomással fúrja át!
 CZ Použijte dřevěný podklad!
 Přitlačte čelo, použijte ostrý vrták a provrtejte pomocí malého tlaku!
 SLO Uporabite leseno podlaglo!
 Pritisnite ličnico ter z ostrim svedrom in z majhnim pritiskom izvrtaite luknjo!
 FIN Käytä puualustaa!
 Paina etulevy paikoilleen, käytä terävää poranterää ja poraa reikä vain kevyesti painamalla!
 S Använd ett träunderlag!
 Tryck fronten mot underlaget, använd vass borr och borra igenom med ett lätt tryck!
 SK Použite drevený podklad!
 Pritlačte front, použite ostrý vrták a prevrtajte miernym tlakom!
 RO suport de lemn! Împingeți frontul, utilizați un burghiu ascuțit și perforați exercitând doar o presiune redusă!
 TR Ahşap taban kullanın!
 Önden bastırın, keskin matkap ucu kullanın ve az basınç uygulayarak delin!

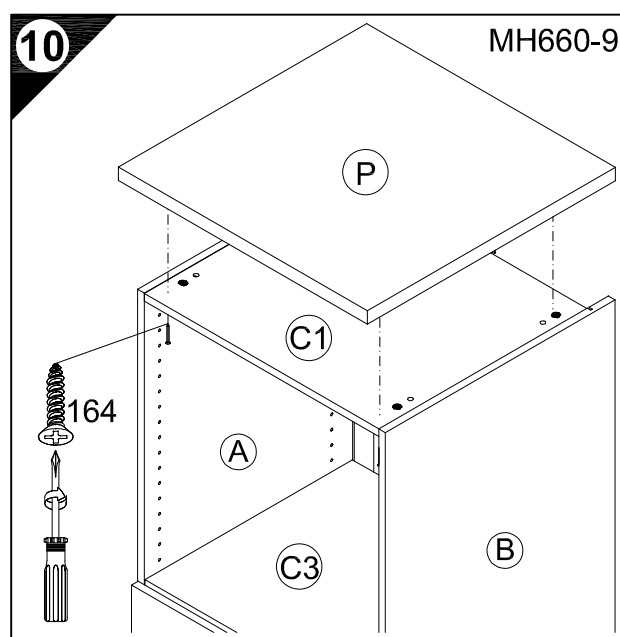
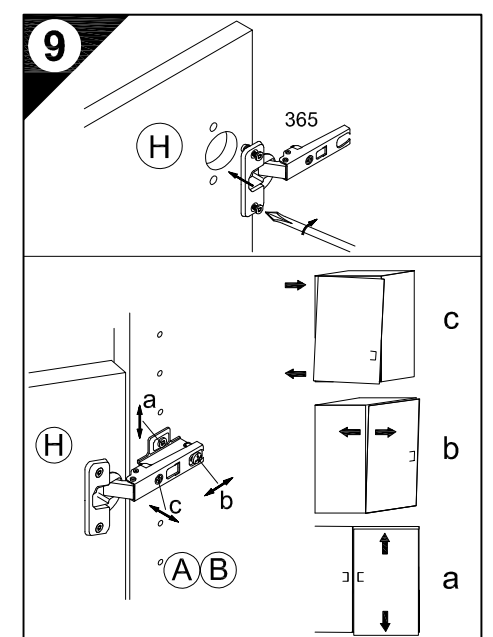

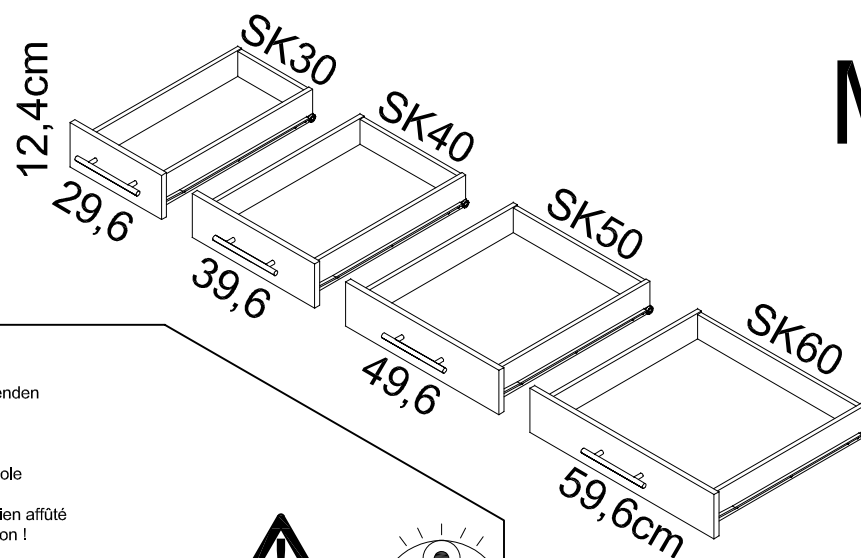
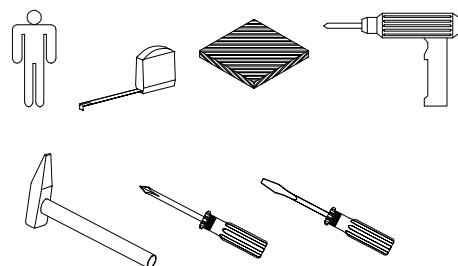

Montageanleitung

1 → 2 → 3 ...

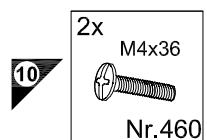
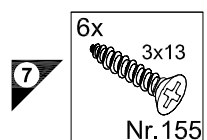
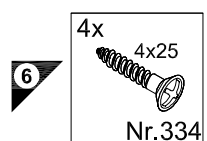
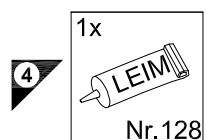
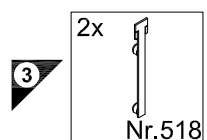

1

D Holzunterlage verwenden!
Front andrücken, scharfen Bohrer verwenden und mit wenig Druck durchbohren!

GB Use a wooden base!
Press front down, use sharp drill bit and, by applying slight pressure, drill a hole

F Utiliser un support en bois !
Appuyer sur la façade, utiliser un foret bien affûté et percer en appliquant une faible pression !

NL Houten onderlegger gebruiken!
Druk het front aan, gebruik een scherpe boor en oefen bij het boren weinig druk uit!

E Utilizar una base de madera!
Presionar el frente, utilizar una broca afilada y taladrar con poca presión!

I Utilizzare una base di legno!
Appoggiare la facciata, utilizzare una punta di trapano affilata e trapanare esercitando solo una leggera pressione!

RUS Использовать деревянную подложку!
Прижать фасад, использовать острое сверло и просверлить с незначительным давлением!

PL Używać podkładkę z drewna!
Docisnąć front, użyć ostrego wiertła i przewiercić, używając małej siły nacisku!

H Alkalmazzon fa alátétet!
Nyomja le az előlapot, használjon éles fúrót, és kis nyomással fúrja át!

CZ Použijte dřevěný podklad!
Přitlačte čelo, použijte ostrý vrták a provrtajte pomocí malého tlaku!

SLO Uporabite leseno podlago!
Pritisnite ličnico ter z ostrim svedrom in z majhnim pritiskom izvrtajte luknjo!

FIN Käytä puualustaa!
Paina etulevy paikoilleen, käytä terävää poranterää ja poraa reikä vain kevyesti painamalla!

S Använd ett träunderlag!
Tryck fronten mot underlaget, använd vass borr och borra igenom med ett lätt tryck!

SK Použite drevený podklad!
Přitlačte front, použijte ostrý vrták a prevrtajte miernym tlakom!

RO suport de lemn! Împingeți frontul, utilizați un burghiu ascuțit și perforați exercitând doar o presiune redusă!

TR Ahşap taban kullanın!
Önden bastrın, keskin matkap ucu kullanın ve az basınç uygulayarak delin!

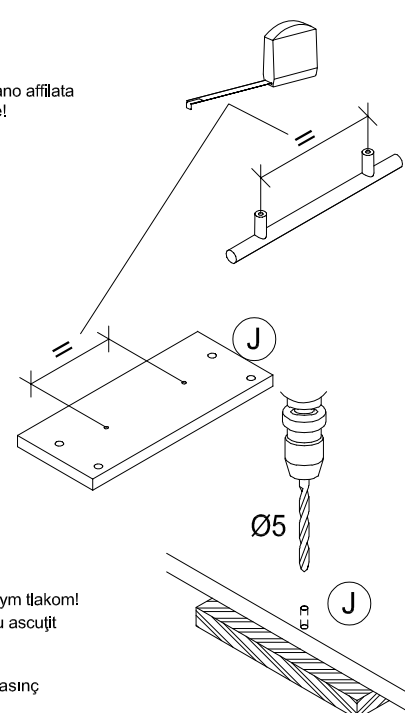
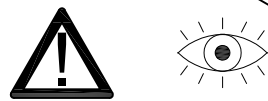

Service-Hotline
01805-678101
0,14€ pro Minute
++49 für Österreich
Auslandstarif pro Minute
service@jaka-bkl.de
voor Nederland en België
00800-40119350
benelux@jaka-bkl.de

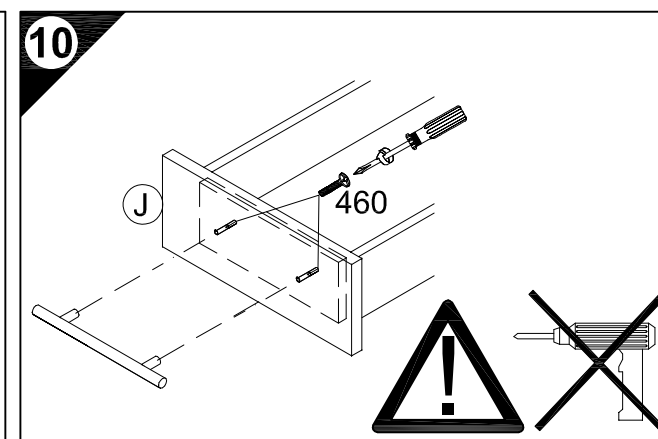
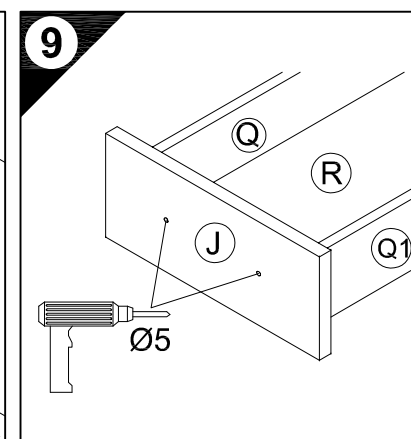
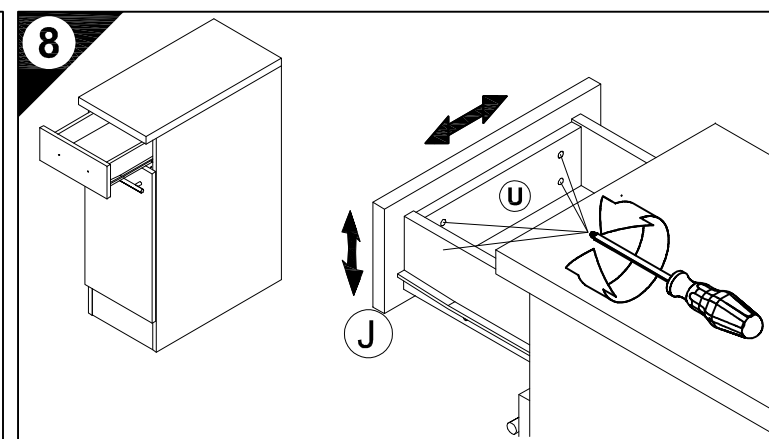
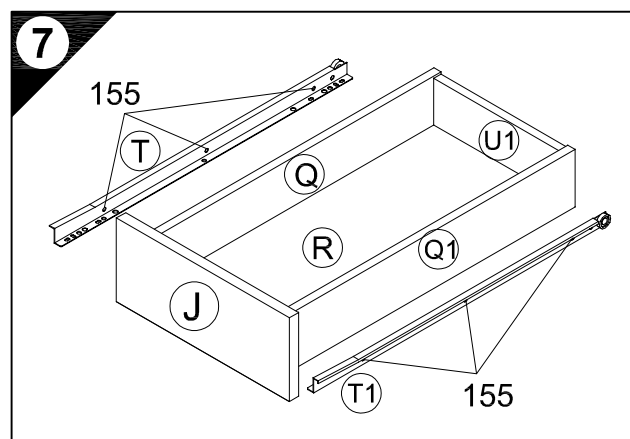
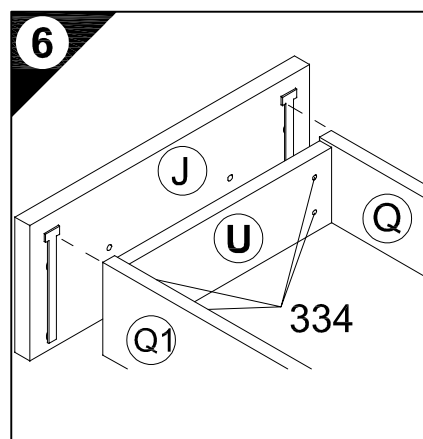
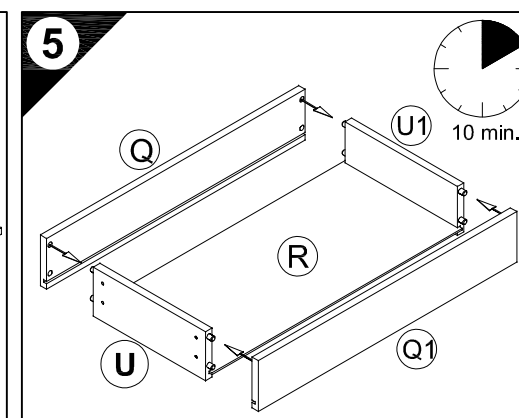
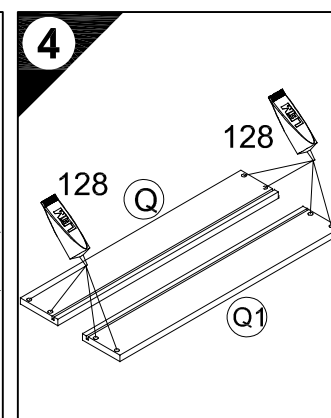
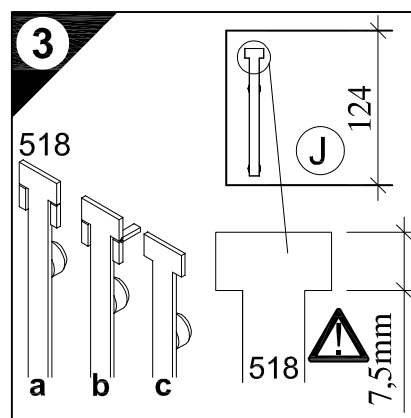
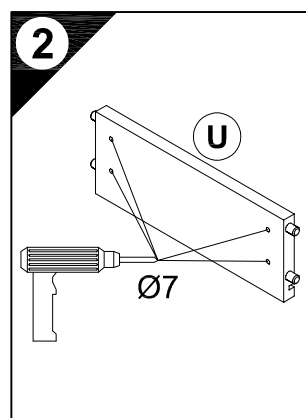
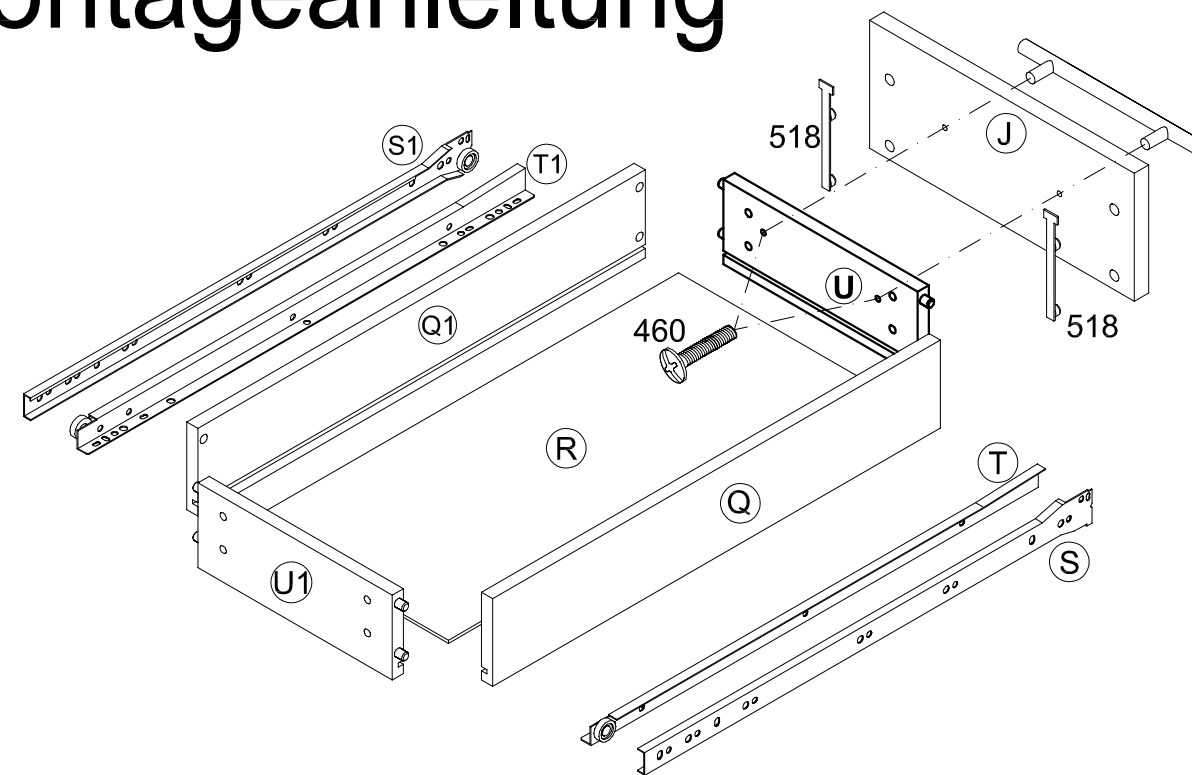

Ersatzteile/Spare parts/pièces de rechange/Reserveonderdelen/Piezas de recambio/Ricambi/Запасные части/Części zamienne/pótalkatrészek/Náhradní části/Nadomestni deli/varaosat/reservdelar/náhradné diely/Utilizați piese de schimb/Yedek parçalar

SK 30	J E940565	Q E945400	Q1 E945400	R E970153	S E946155	S1 E946155	T E946155	T1 E946155	U E945405	U1 E945405
SK 40	J E940564	Q E945400	Q1 E945400	R E970152	S E946155	S1 E946155	T E946155	T1 E946155	U E945406	U1 E945406
SK 50	J E940563	Q E945400	Q1 E945400	R E970151	S E946155	S1 E946155	T E946155	T1 E946155	U E945407	U1 E945407
SK 60	J E940562	Q E945400	Q1 E945400	R E970150	S E946155	S1 E946155	T E946155	T1 E946155	U E945408	U1 E945408

